

1 SAFETY PRECAUTIONS

The precautions listed here are divided into the following types. They are quite important, so be sure to follow them carefully. Meanings of DANGER, WARNING, CAUTION and NOTE symbols.

INFORMATION

- Read these instructions carefully before installation. Keep this manual in a handy for future reference.
- Improper installation of equipment or accessories may result in electric shock, short-circuit, leakage, fire or other damage to the equipment. Be sure to only use accessories made by the supplier, which are specifically designed for the equipment and make sure to get installation done by a professional.
- All the activities described in this manual must be carried out by a licensed technician. Be sure to wear adequate personal protection equipment such as gloves and safety glasses while installation the unit or carrying out maintenance activities.
- Contact your dealer for any further assistance.

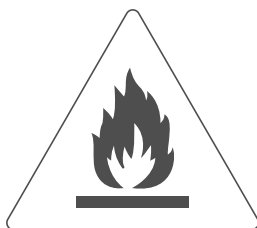

Caution: Risk of fire/
flammable materials

WARNING

Servicing shall only be performed as recommended by the equipment manufacturer. Maintenance and repair requiring the assistance of other skilled personnel shall be carried out under the supervision of the person competent in the use of flammable refrigerants.

DANGER

Indicates an imminently hazardous situation which if not avoided, will result in death or serious injury.

WARNING

Indicates a potentially hazardous situation which if not avoided, could result in death or serious injury.





CAUTION

Indicates a potentially hazardous situation which if not avoided, may result in minor or moderate injury. It is also used to alert against unsafe practices.

NOTE

Indicates situations that could only result in accidental equipment or property damage.

Explanation of symbols displayed on the indoor unit or outdoor unit

	WARNING	This symbol shows that this appliance used a flammable refrigerant. If the refrigerant is leaked and exposed to an external ignition source, there is a risk of fire.
	CAUTION	This symbol shows that the operation manual should be read carefully.
	CAUTION	This symbol shows that a service personnel should be handling this equipment with reference to the installation manual.
	CAUTION	This symbol shows that a service personnel should be handling this equipment with reference to the installation manual.
	CAUTION	This symbol shows that information is available such as the operating manual or installation manual.

DANGER

- Before touching electric terminal parts, turn off power switch.
- When service panels are removed, live parts can be easily touched by accident.
- Never leave the unit unattended during installation or servicing when the service panel is removed.
- Do not touch water pipes during and immediately after operation as the pipes may be hot and could burn your hands. To avoid injury, give the piping time to return to normal temperature or be sure to wear protective gloves.
- Do not touch any switch with wet fingers. Touching a switch with wet fingers can cause electrical shock.
- Before touching electrical parts, turn off all applicable power to the unit.

WARNING

- Tear apart and throw away plastic packaging bags so that children will not play with them. Children playing with plastic bags face danger of death by suffocation.
- Safely dispose of packing materials such as nails and other metal or wood parts that could cause injuries.
- Ask your dealer or qualified personnel to perform installation work in accordance with this manual. Do not install the unit yourself. Improper installation could result in water leakage, electric shocks or fire
- Be sure to use only specified accessories and parts for installation work. Failure to use specified parts may result in water leakage, electric shocks, fire, or the unit falling from its mount.
- Install the unit on a foundation that can withstand its weight. Insufficient physical strength may cause the equipment to fall and possible injury.
- Perform specified installation work with full consideration of strong wind, hurricanes, or earthquakes. Improper installation work may result in accidents due to equipment falling.
- Make certain that all electrical work is carried out by qualified personnel according to the local laws and regulations and this manual using a separate circuit. Insufficient capacity of the power supply circuit or improper electrical construction may lead to electric shocks or fire.
- Be sure to install a ground fault circuit interrupter according to local laws and regulations. Failure to install a ground fault circuit interrupter may cause electric shocks and fire.
- Make sure all wiring is secure. Use the specified wires and ensure that terminal connections or wires are protected from water and other adverse external forces. Incomplete connection or affixing may cause a fire.
- When wiring the power supply, form the wires so that the front panel can be securely fastened. If the front panel is not in place there could be overheating of the terminals, electric shocks or fire.
- After completing the installation work, check to make sure that there is no refrigerant leakage.
- Never directly touch any leaking refrigerant as it could cause severe frostbite. Do not touch the refrigerant pipes during and immediately after operation as the refrigerant pipes may be hot or cold, depending on the condition of the refrigerant flowing through the refrigerant piping, compressor and other refrigerant cycle parts. Burns or frostbite are possible if you touch the refrigerant pipes. To avoid injury, give the pipes time to return to normal temperature or, if you must touch them be sure to wear protective gloves.
- Do not touch the internal parts (pump, backup heater, etc.) during and immediately after operation. Touching the internal parts can cause burns. To avoid injury, give the internal parts time to return to normal temperature or, if you must touch them, be sure to wear protective gloves.

CAUTION

- Ground the unit.
- Grounding resistance should be according to local laws and regulations.
- Do not connect the ground wire to gas or water pipes, lightning conductors or telephone ground wires.
- Incomplete grounding may cause electric shocks.
 - Gas pipes: Fire or an explosion might occur if the gas leaks.
 - Water pipes: Hard vinyl tubes are not effective grounds.
 - Lightning conductors or telephone ground wires: Electrical threshold may rise abnormally if struck by a lightning bolt.
- Install the power wire at least 3 feet (1 meter) away from televisions or radios to prevent interference or noise. (Depending on the radio waves, a distance of 3 feet (1 meter) may not be sufficient to eliminate the noise.)
- Do not wash the unit. This may cause electric shocks or fire. The appliance must be installed in accordance with national wiring regulations. If the supply cord is damaged, it must be replaced by the manufacturer, its service agent or similarly qualified persons in order to avoid a hazard.





- Do not install the unit in the following places:
 - Where there is mist of mineral oil, oil spray or vapors. Plastic parts may deteriorate, and cause them to come loose or water to leak.
 - Where corrosive gases (such as sulphurous acid gas) are produced. Where corrosion of copper pipes or soldered parts may cause refrigerant to leak.
 - Where there is machinery which emits electromagnetic waves. Electromagnetic waves can disturb the control system and cause equipment malfunction.
 - Where flammable gases may leak, where carbon fiber or ignitable dust is suspended in the air or where volatile flammables such as paint thinner or gasoline are handled. These types of gases might cause a fire.
 - Where the air contains high levels of salt such as near the ocean.
 - Where voltage fluctuates a lot, such as in factories.
 - In vehicles or vessels.
 - Where acidic or alkaline vapors are present.
- This appliance can be used by children 8 years old and above and persons with reduced physical, sensory or mental capabilities or lack of experience and knowledge if they are supervised or given instruction on using the unit in a safe manner and understand the hazards involved. Children should not play with the unit. Cleaning and user maintenance should not be done by children without supervision.
- Children should be supervised to ensure that they do not play with the appliance.
If the supply cord is damaged, it must be replaced by the manufacturer or its service agent or a similarly qualified person.
- DISPOSAL: Do not dispose this product as unsorted municipal waste. Collection of such waste separately for special treatment is necessary. Do not dispose of electrical appliances as municipal waste, use separate collection facilities. Contact your local government for information regarding the collection systems available. If electrical appliances are disposed of in landfills or dumps, hazardous substance can leak into the groundwater and get into the food chain, damaging your health and well-being.
- The wiring must be performed by professional technicians in accordance with national wiring regulation and this circuit diagram. An all-pole disconnection device which has at least 3mm separation distance in all pole and a residualcurrent device(RCD) with the rating not exceeding 30mA shall be incorporated in the fixed wiring according to the national rule.
- Confirm the safety of the installation area (walls, floors, etc.) without hidden dangers such as water, electricity, and gas. Before wiring/pipes.
- Before installation , check whether the user's power supply meets the electrical installation requirements of unit (including reliable grounding , leakage , and wire diameter electrical load, etc.). If the electrical installation requirements of the product are not met, the installation of the product is prohibited until the product is rectified.
- When installing multiple air conditioners in a centralized manner, please confirm the load balance of the three-phase power supply, and multiple units are prevented from being assembled into the same phase of the three-phase power supply.
- Product installation should be fixed firmly, Take reinforcement measures, when necessary.

💡 NOTE

- About Fluorinated Gasses
 - This air-conditioning unit contains fluorinated gasses. For specific information on the type of gas and the amount, please refer to the relevant label on the unit itself. Compliance with national gas regulations shall be observed.
 - Installation, service, maintenance and repair of this unit must be performed by a certified technician.
 - Product uninstallation and recycling must be performed by a certified technician.
 - If the system has a leak-detection system installed, it must be checked for leaks at least every 12 months. When the unit is checked for leaks, proper record-keeping of all checks is strongly recommended.

2 ACCESSORIES

2.1 Accessories supplied with the unit

Installation Fittings		
Name	Shape	Quantity
Outdoor unit installation & owners manual (this book)		1
Technical data manual		1
Water outlet connection pipe assembly		1
Energy label		1

3 BEFORE INSTALLATION

- **Before installation**

Be sure to confirm the model name and the serial number of the unit.

- **Handling**

1. Handle the unit using the sling to the left and the right .Pull up both sides of the sling at the same time to prevent disconnection of the sling from the unit.

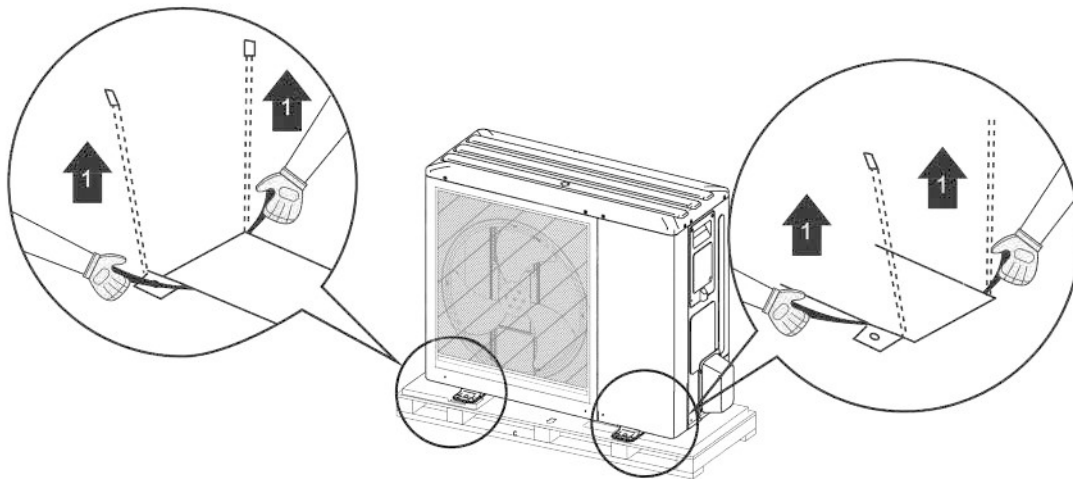

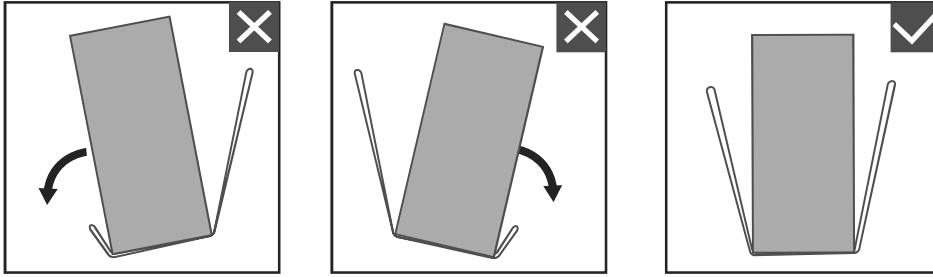

2. While handling the unit
- keep both sides of the sling level.
 - keep your back straight

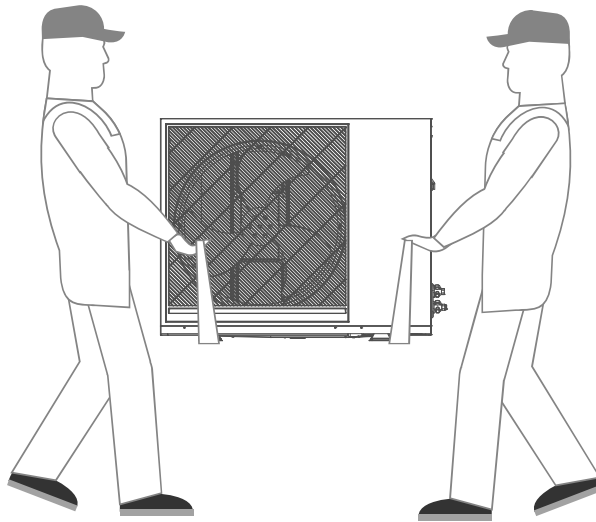

3. After mounting the unit, remove the sling from the unit by pulling 1 side of the sling.

⚠ CAUTION

- To avoid injury, do not touch the air inlet and aluminum fins of the unit.
- Do not use the grips in the fan grills to avoid damage.
- The unit is top heavy! Prevent the unit from falling due to improper inclination during handling.

EN

4 IMPORTANT INFORMATION FOR THE REFRIGERANT

This product has the fluorinated gas, it is forbidden to release to air.

Refrigerant type: R32; Volume of GWP: 675.

GWP=Global Warming Potential

Model	Factory charged refrigerant volume in the unit	
	Refrigerant/kg	Tonnes CO ₂ equivalent
4kW	1.40	0.95
6kW	1.40	0.95
8kW	1.50	1.02
10kW	1.60	1.08

Model	Factory charged refrigerant volume in the unit	
	Refrigerant/kg	Tonnes CO ₂ equivalent
3-phase 12kW	1.75	1.18
3-phase 14kW	1.84	1.24
3-phase 16kW	1.84	1.24

CAUTION

- Frequency of Refrigerant Leakage Checks
 - Equipment that contains less than 3 kg of fluorinated greenhouse gases or hermetically sealed equipment, which is labelled accordingly and contains less than 6 kg of fluorinated greenhouse gases shall not be subject to leak checks.
 - For unit that contains fluorinated greenhouse gases in quantities of 5 tonnes of CO₂ equivalent or more, but of less than 50 tonnes of CO₂ equivalent, at least every 12 months, or where a leakage detection system is installed, at least every 24 months.
 - Only certificated person is allowed to do installation, operation and maintenance.

5 INSTALLATION SITE

WARNING

- Be sure to adopt adequate measures to prevent the unit from being used as a shelter by small animals. Small animals making contact with electrical parts can cause malfunction, smoke or fire. Please instruct the customer to keep the area around the unit clean.
- Select an installation site where the following conditions are satisfied and one that meets with your customer's approval.
 - Places that are well-ventilated.
 - Places where the unit does not disturb next-door neighbors.
 - Safe places which can bear the unit's weight and vibration and where the unit can be installed at an even level.
 - Places where there is no possibility of flammable gas or product leak.
 - The equipment is not intended for use in a potentially explosive atmosphere.
 - Places where servicing space can be well ensured.
 - Places where the units' piping and wiring lengths come within the allowable ranges.
 - Places where water leaking from the unit cannot cause damage to the location (e.g. in case of a blocked drain pipe).
 - Places where rain can be avoided as much as possible.
 - Do not install the unit in places often used as a work space. In case of construction work (e.g. grinding etc.) where a lot of dust is created, the unit must be covered.
 - Do not place any object or equipment on top of the unit (top plate)
 - Do not climb, sit or stand on top of the unit.
 - Be sure that sufficient precautions are taken in case of refrigerant leakage according to relevant local laws and regulations.- Don't install the unit near the sea or where there is corrosion gas.
- When installing the unit in a place exposed to strong wind, pay special attention to the following.
- Strong winds of 5 m/sec or more blowing against the unit's air outlet causes a short circuit (suction of discharge air), and this may have the following consequences:
 - Deterioration of the operational capacity.
 - Frequent frost acceleration in heating operation.
 - Disruption of operation due to rise of high pressure.
 - Motor burnout.
 - When a strong wind blows continuously on the front of the unit, the fan can start rotating very fast until it breaks.

In normal condition, refer to the figures below for installation of the unit:

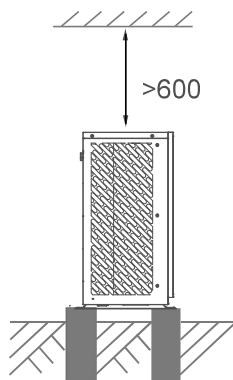
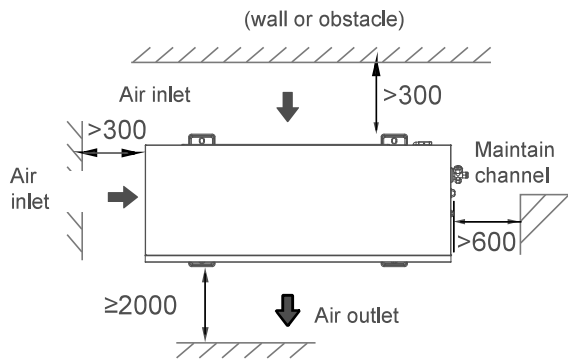

4/6/8/10/12/14/16 kW (unit: mm)

NOTE

- Make sure there is enough space to do the installation. Set the outlet side at a right angle to the direction of the wind.
- Prepare a water drainage channel around the foundation, to drain waste water from around the unit.
- If water does not easily drain from the unit, mount the unit on a foundation of concrete blocks, etc. (the height of the foundation should be about 300 mm, (in Fig:6-3)
- When installing the unit in a place frequently exposed to snow, pay special attention to elevate the foundation as high as possible.
- If you install the unit on a building frame, please install a waterproof plate (field supply) (about 100mm, on the underside of the unit) in order to avoid drain water dripping. (See the picture in the right).



5.1 Selecting a location in cold climates

Refer to "Handling" in section "4 Before installation"

NOTE

When operating the unit in cold climates, be sure to follow the instructions described below.

- To prevent exposure to wind, install the unit with its suction side facing the wall.
- Never install the unit at a site where the suction side may be exposed directly to wind.
- To prevent exposure to wind, install a baffle plate on the air discharge side of the unit.
- In heavy snowfall areas, it is very important to select an installation site where the snow will not affect the unit. If lateral snowfall is possible, make sure that the heat exchanger coil is not affected by the snow (if necessary construct a lateral canopy).

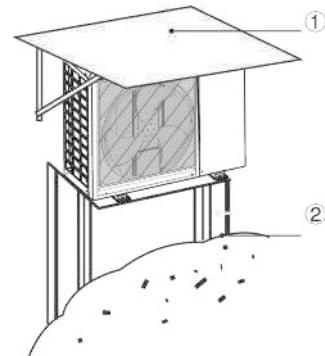

① Construct a large canopy.

② Construct a pedestal.

Install the unit high enough off the ground to prevent it from being buried in snow.

5.2 Prevent sunshine

As the outdoor temperature is measured via the outdoor unit air thermistor, make sure to install the outdoor unit in the shade or a canopy should be constructed to avoid direct sunlight, so that it is not influenced by the sun's heat, otherwise protection may be possible to the unit.

WARNING

Uncovered scene, anti-snow shed must be installed: (1) to prevent rain and snow from hitting the heat exchanger, resulting in poor heating capacity of the unit, after long time accumulation, the heat exchanger freezes; (2) To prevent the outdoor unit air thermistor from being exposed to the sun, resulting in failure to boot; (3) To prevent freezing rain.

6 INSTALLATION PRECAUTIONS

6.1 Dimensions

4/6/8 kW (unit: mm)

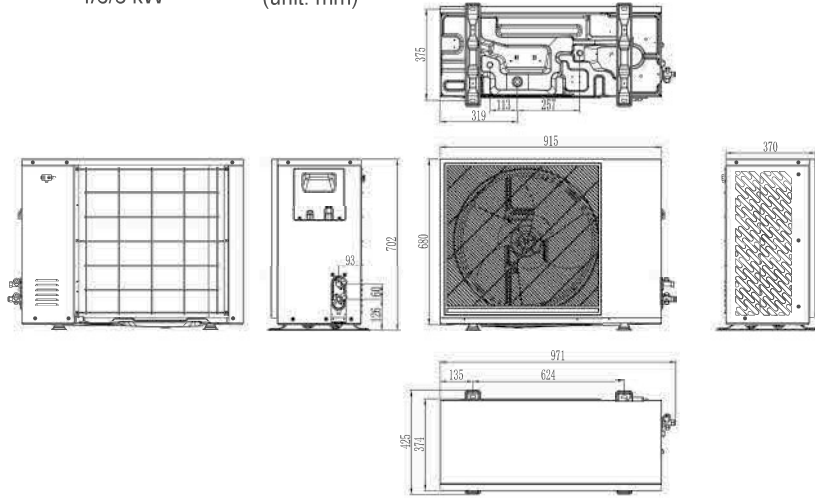

10/12 kW (unit: mm)

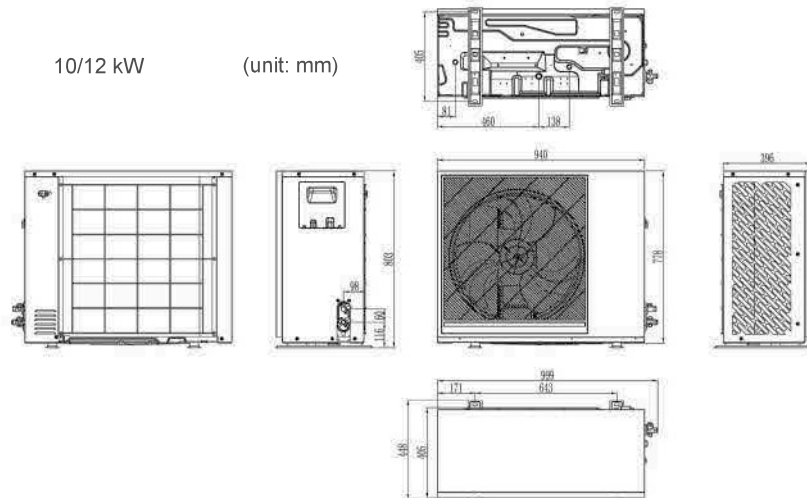

14/16 kW (unit: mm)

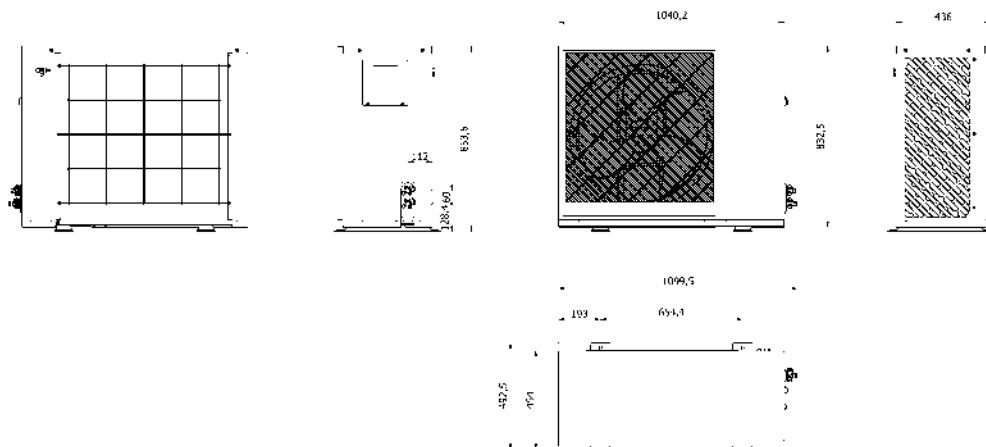

6.2 Installation requirements

- Check the strength and level of the installation ground so that the unit may not cause any vibrations or noise during the operation.
- In accordance with the foundation drawing in the figure, fix the unit securely by means of foundation bolts. (Prepare four sets each of $\Phi 10$ Expansion bolts, nuts and washers which are readily available in the market.)
- Screw in the foundation bolts until their length is 20 mm from the foundation surface.

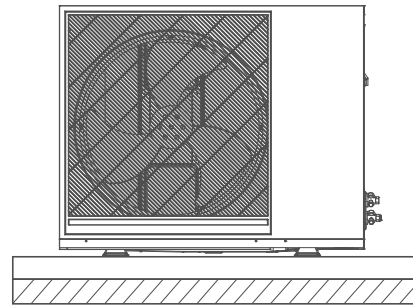
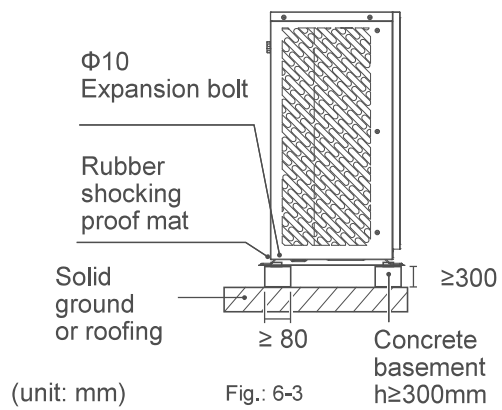

Fig: 6-4

6.3 Drain hole position

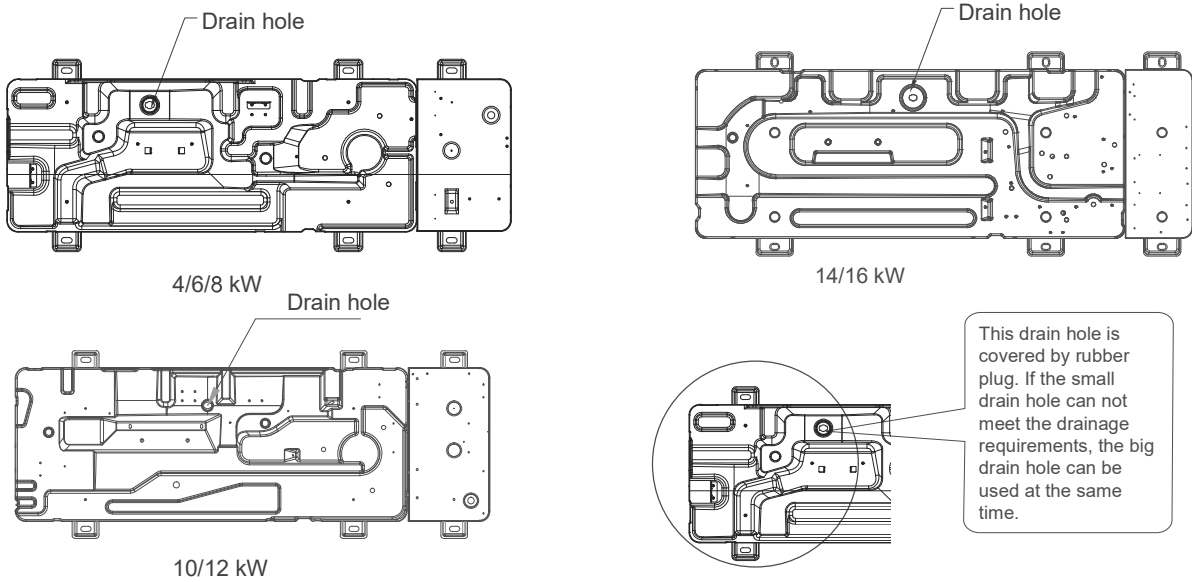

Fig: 6-5

CAUTION

It's necessary to install an electrical heating belt if water can't drain out in cold weather even the big drain hole has opened.

It is suggested to site the unit with the base electric heater.

6.4 Installation space requirements

6.4.1 In case of stacked installation

1) In case obstacles exist in front of the outlet side.

2) In case obstacles exist in front of the air inlet.

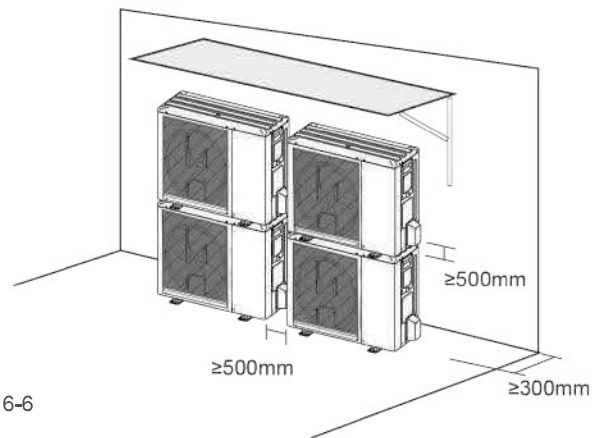
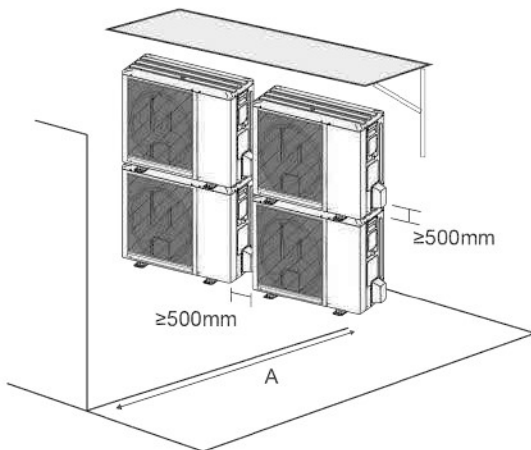

Fig: 6-6

Unit	A(mm)
4~16kW	≥ 2000

NOTE

It's necessary to install the water outlet connection pipe assembly if the unit is mounted on the top of each other, preventing condensate flow to the heat exchanger.

6.4.2 In case of multiple-row installation

1) In case of installing one unit per row.

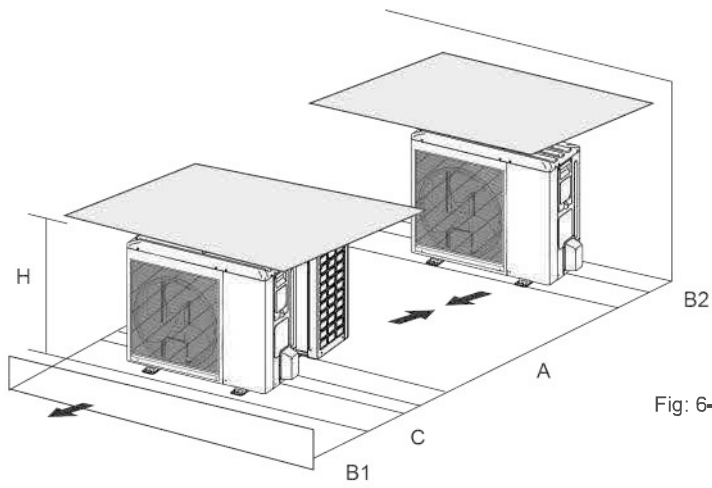

Fig: 6-7

Unit	A(mm)	B1(mm)	B2(mm)	C(mm)
4~16kW	≥3000	≥2000	≥150	≥600

2) In case of installing multiple units in lateral connection per row.

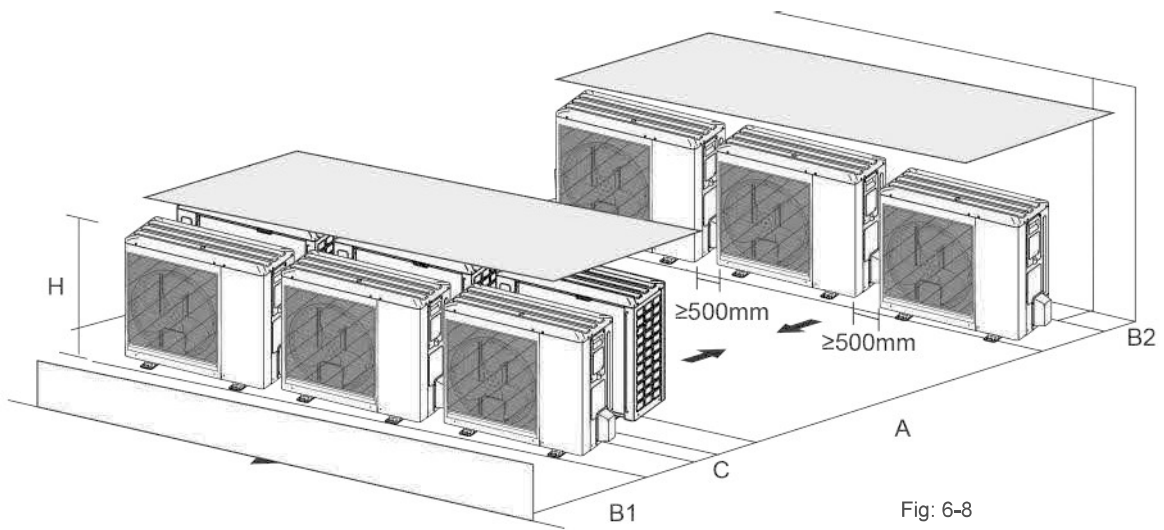

Fig: 6-8

Unit	A(mm)	B1(mm)	B2(mm)	C(mm)
4~16kW	≥3000	≥2000	≥300	≥600

7 INSTALLATION THE CONNECTING PIPE

7.1 Refrigerant piping

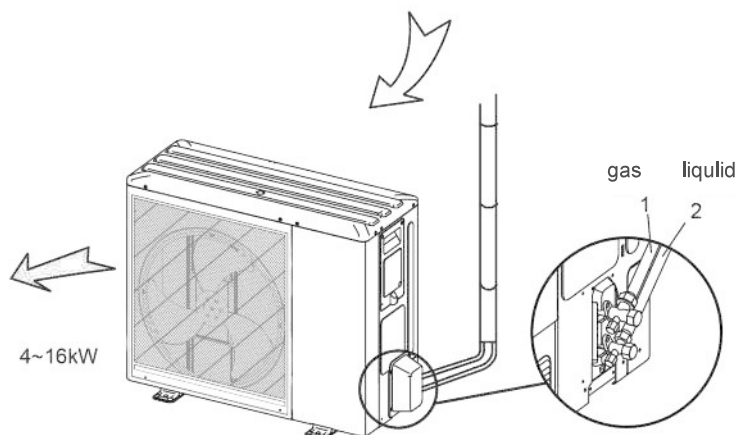

Fig.7-1

CAUTION

- Please pay attention to avoid the components where it is connecting to the connecting pipes.
- To prevent the refrigerant piping from oxidizing inside when welding, it is necessary to charge nitrogen, or oxide will clog the circulation system.

7.2 Leakage detection

Use soap water or leakage detector to check every joint whether leak or not (Refer to Fig.7-2).Note:

A is high pressure side stop valve

B is low pressure side stop valve

C and D is connecting pipes interface of indoor and outdoor units

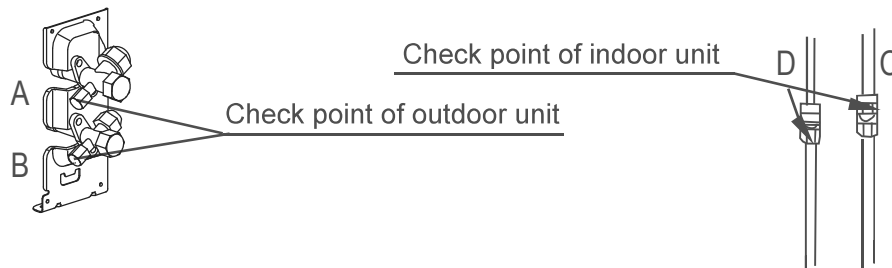

Fig.7-2

7.3 Heat insulation

In order to avoid the release of cold or heat from the connecting pipeline to the external environment during the operation of the equipment, please take effective insulation measures for the gas pipe and liquid pipe separately

- 1) The gas side pipe should use closed cell foamed insulation material, which the fire-retardant is B1 grade and the heat resistance over 120 °C.
- 2) When the external diameter of copper pipe $\leq \Phi 12.7\text{mm}$, the thickness of the insulating layer at least more than 15mm; When the external diameter of copper pipe $\geq \Phi 15.9\text{mm}$, the thickness of the insulating layer at least more than 20mm.
- 3) Please use attached heat-insulating materials do the heat insulation without clearance for the connecting parts of the indoor unit pipes.

7.4 Connecting method

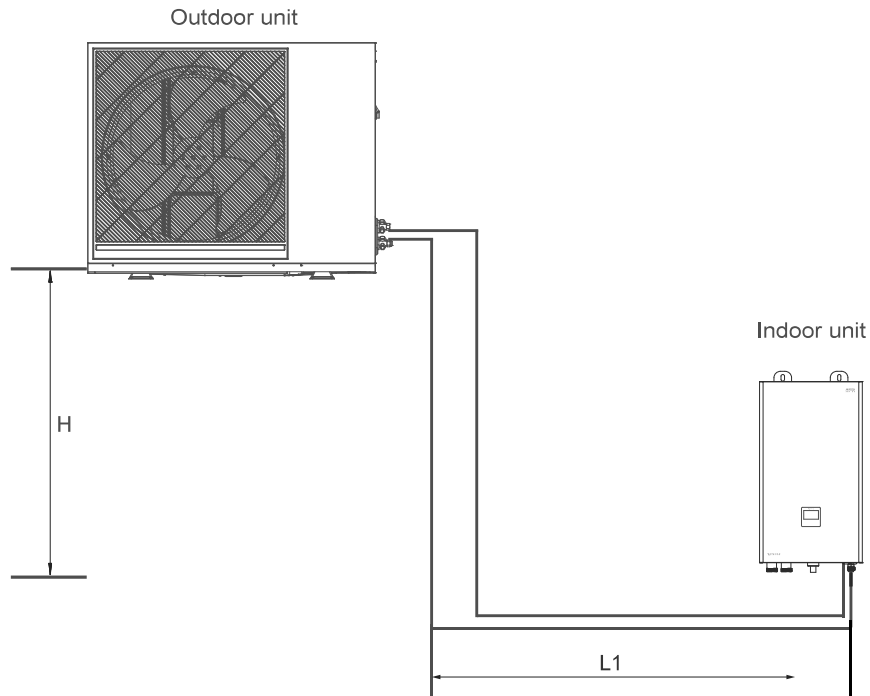

Figure 7-5

Models	4~16 kW
Max.piping length (H+L1)	15m
Max difference in height (H)	8m
Min.piping length (H+L1)	3m

1) Size of pipes of Gas side and Liquid side

MODEL	Refrigerant	Gas side/Liquid side
4/6kW	R32	Φ15.9/Φ6.35
8/10kW	R32	Φ15.9/Φ9.52
3-phase 12/14/16kW	R32	Φ15.9/Φ9.52

2) Connection method

	Gas side	Liquid side
4~16kW outdoor unit	Flaring	Flaring
Indoor unit	Flaring	Flaring

7.5 Remove dirt or water in the pipes

- 1) Make sure there is no any dirt or water before connecting the piping to the outdoor and indoor units.
- 2) Wash the pipes with high pressure nitrogen, never use refrigerant of outdoor unit.

7.6 Airtight testing

Charge pressured nitrogen after connecting indoor/outdoor unit pipes to do airtight testing.



CAUTION

Pressured nitrogen [4.3MPa (44kg/cm²) for R32] should be used in the airtight testing.

Tighten high/low pressure valves before charging pressured nitrogen.

Charge pressure nitrogen from the connector on the pressure valves.

The airtight testing should never use any oxygen, flammable gas or poisonous gas.

7.7 Air purge with vacuum pump

- 1) Using vacuum pump to do the vacuum, never using refrigerant to expel the air.
- 2) Vacuuming should be done from liquid side .

7.8 Refrigerant amount to be added

Calculate the added refrigerant according to the diameter and the length of the liquid side pipe of the outdoor unit/indoor unit connection. If the length of the liquid side pipe is less than 7,5 meters it is no need to add more refrigerant ,so than calculating the added refrigerant the length of the liquid side pipe must subtract 7,5 meters.

Refrigerant to be added	Model	Total liquid pipe length L(m)	
		≤7,5m	>7,5m
Total additional refrigerant	4/6kW	0g	(L-15)×20g
	8/10/12/14/16kW	0g	(L-15)×38g

8 OUTDOOR UNIT WIRING



WARNING

A main switch or other means of disconnection, having a contact separation in all poles, must be incorporated in the fixed wiring in accordance with relevant local laws and regulations. Switch off the power supply before making any connections. Use only copper wires. Never squeeze bundled cables and make sure they do not come in contact with the piping and sharp edges. Make sure no external pressure is applied to the terminal connections. All field wiring and components must be installed by a licensed electrician and must comply with relevant local laws and regulations.

The field wiring must be carried out in accordance with the wiring diagram supplied with the unit and the instructions given below.

Be sure to use a dedicated power supply. Never use a power supply shared by another appliance.

Be sure to establish a ground. Do not ground the unit to a utility pipe, surge protector, or telephone ground. Incomplete grounding may cause electrical shock.

Be sure to install a ground fault circuit interrupter (30 mA). Failure to do so may cause electrical shock.

Be sure to install the required fuses or circuit breakers.

8.1 Precautions on electrical wiring work

- Fix cables so that cables do not make contact with the pipes (especially on the high pressure side).
- Secure the electrical wiring with cable ties as shown in figure so that it does not come in contact with the piping, particularly on the high-pressure side.
- Make sure no external pressure is applied to the terminal connectors.
- When installing the ground fault circuit interrupter make sure that it is compatible with the inverter (resistant to high frequency electrical noise) to avoid unnecessary opening of the ground fault circuit interrupter.



NOTE

The ground fault circuit interrupter must be a high-speed type breaker of 30 mA (<0.1 s).

- This unit is equipped with an inverter. Installing a phase advancing capacitor not only will reduce the power factor improvement effect, but also may cause abnormal heating of the capacitor due to high-frequency waves. Never install a phase advancing capacitor as it could lead to an accident.

8.2 Precautions on wiring of power supply

- Use a round crimp-style terminal for connection to the power supply terminal board. In case it cannot be used due to unavoidable reasons, be sure to observe the following instructions.
- Do not connect different gauge wires to the same power supply terminal. (Loose connections may cause overheating.)
- When connecting wires of the same gauge, connect them according to the figure below.

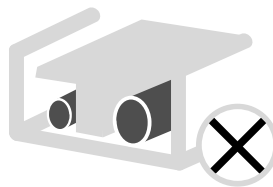
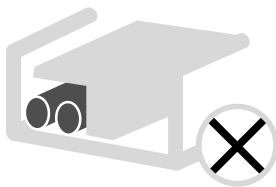
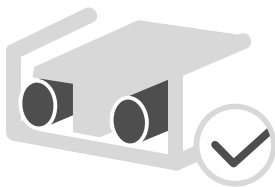

- Use the correct screwdriver to tighten the terminal screws. Small screwdrivers can damage the screw head and prevent appropriate tightening.
- Over-tightening the terminal screws can damage the screws.
- Attach a ground fault circuit interrupter and fuse to the power supply line.
- In wiring, make certain that prescribed wires are used, carry out complete connections, and fix the wires so that outside force cannot affect the terminals.

8.3 Safety device requirement

1. Select the wire diameters individually for each unit based on the table 8-1 the wire diameters should be selected according to the national wiring regulation.
2. Select circuit breaker that having a contact separation in all poles not less than 3 mm providing full disconnection.

Outdoor unit			
	4 / 6kW	8 / 10kW	12 / 14 / 16kW
Minimum rated current of the overcurrent circuit breaker with breaker type [A]	B16	B20	B16
Minimal wire pcs and dimension of cords [pcs x mm2]*	3x2,5	3x4	5x2,5

The residual current circuit breaker used to protect the electrical circuit of the appliance shall be selected in view of the electrical regulations in force, assuming that the rated residual current is not greater than $I\Delta n$: 30mA

*The above values apply to supply cables with a maximum length of 20mb. If this value is exceeded, an electrical designer should be consulted.

- Stated values are maximum values (see electrical data for exact values).

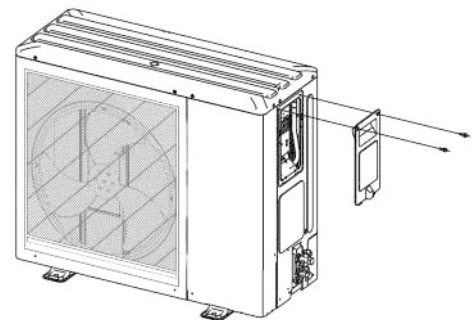
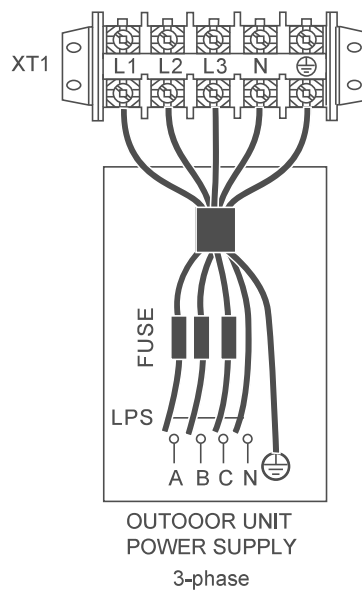
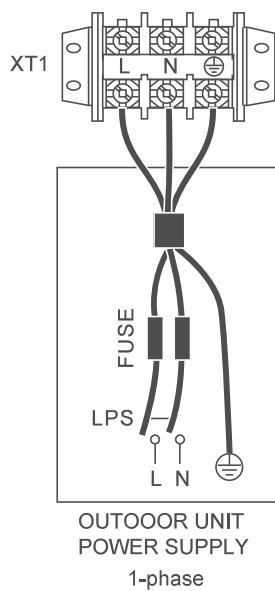



NOTE

The ground fault circuit interrupter must be a high-speed type breaker of 30 mA (<0.1 s).
Please use 3-core shielded wire.

8.4 To finish the outdoor unit installation

insulate and fix the refrigerant piping and interconnection cable as follows:

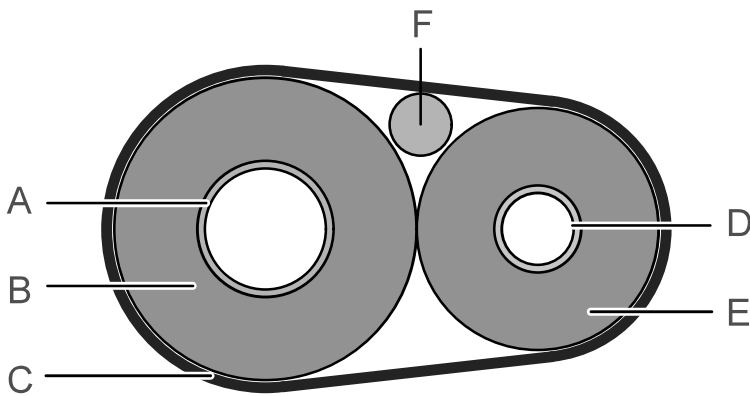

A	Gas pipe
B	Gas pipe insulation
C	Finishing tape
D	Liquid pipe
E	Liquid pipe insulation
F	Interconnection cable

9 OVERVIEW OF THE UNIT

9.1 Disassembling the unit

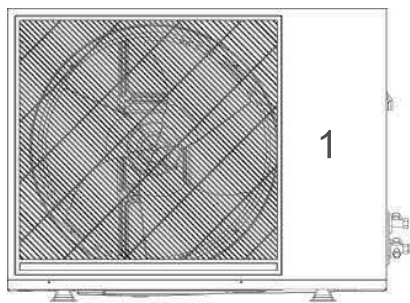

4/6/8kW

Door 1 To access to the compressor and electrical parts

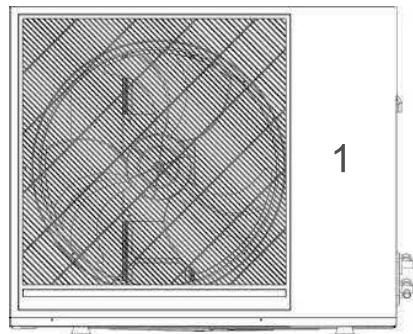

10/12kW

Door 1 To access to the compressor and electrical parts.

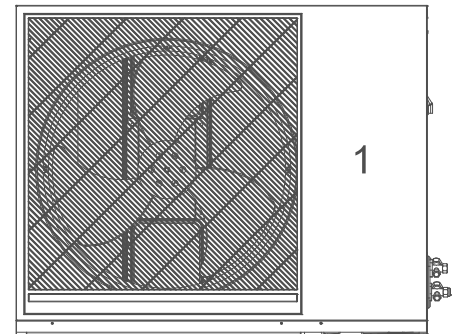

14/16kW

Door 1 To access to the compressor and electrical parts.

EN



WARNING

- Cut off all power supply— i.e. unit power supply and backup heater and domestic hot water tank power supply (if applicable) — before removing doors 1.
- Parts inside the unit may be hot.

9.2 4~16kW 1-phase units

1) PCB A, 4-10kw, Inverter module

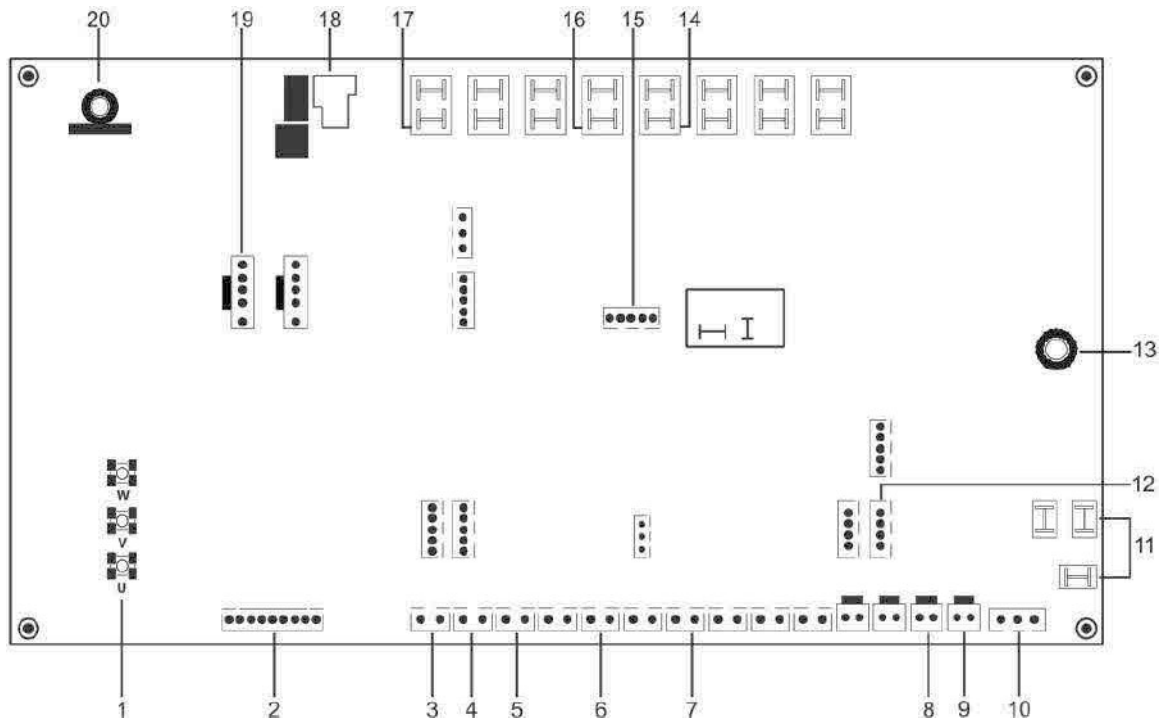

Items	Port label	function	Items	Port label	function
1	U/V/W	Compressor output	11	AC	Power supply
2	JTAG	Drive program update	12	COM4	Communication with hydraulic module PCB
3	TH1	Coil temperature sensor	13	PE1	Port for ground
4	TH2	Outdoor ambient temperature sensor	14	OUT4	Filter components
5	TH3	Refrigerant liquid temperature sensor	15	FLS	PCB Program update
6	TH5	Discharge temperature sensor	16	OUT5	Chassis heater
7	TH7	Suction temperature sensor	17	OUT8	Crankcase heater
8	TS3	HP2: Middle pressure switch	18	K9	Relay for PFC
9	TS4	HP1: High pressure switch	19	FAN1	DC Fan
10	TS5	LPS: Low pressure sensor	20	/	Common mode inductance

2) PCB A, 8-10-12kW, Drive and refrigerant system PCB

Notification: 8kw and 10-12kw models has different PCB A but same connect ports

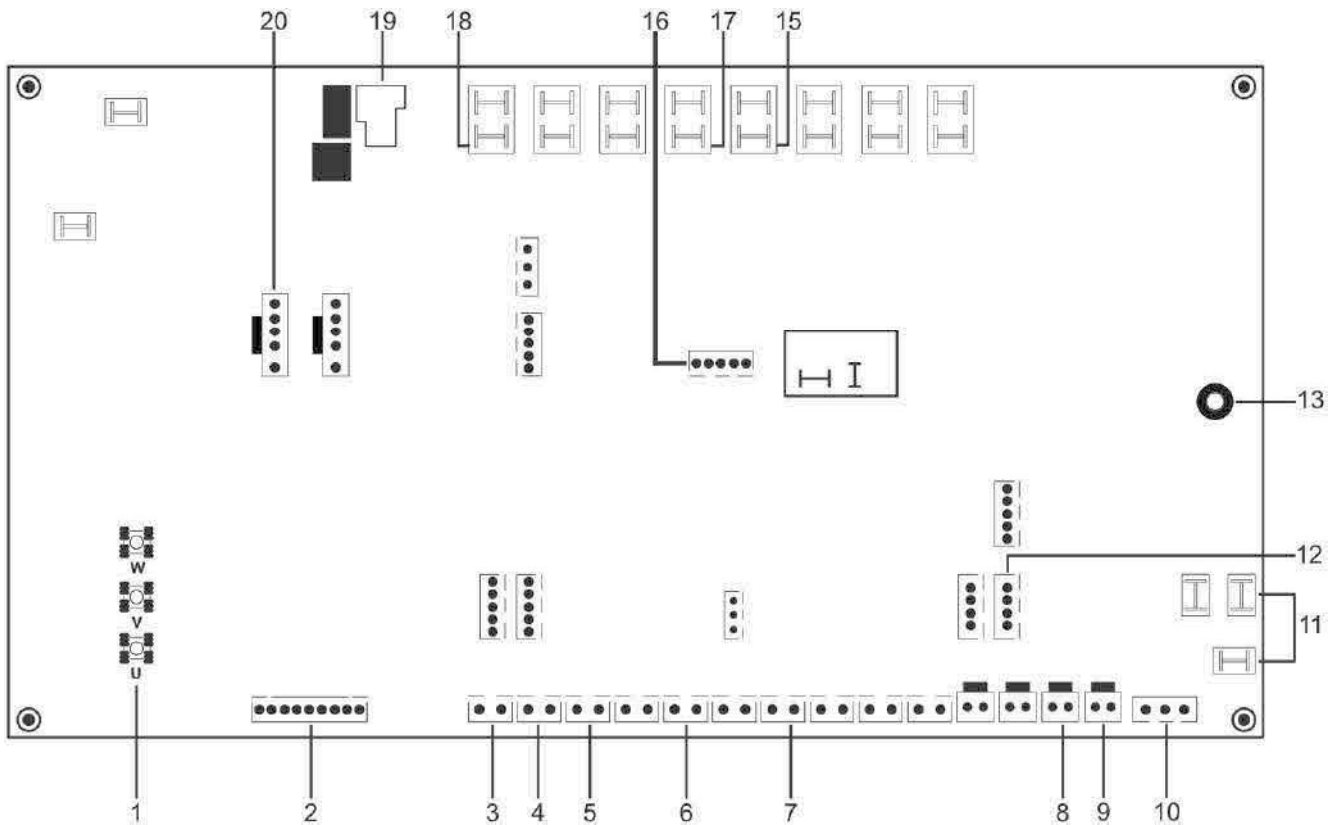

Items	Port label	Function	Items	Port label	Function
1	U/V/W	Compressor output	12	COM4	Communication with hydraulic module PCB
2	JTAG	Drive program update	13	PE1	Port for ground
3	TH1	Coil temperature sensor	14	/	Filter components
4	TH2	Outdoor ambient temperature sensor	15	OUT4	Filter components
5	TH3	Refrigerant liquid temperature sensor	16	FLS	PCB Program update
6	TH5	Discharge temperature sensor	17	OUT5	Chassis heater
7	TH7	Suction temperature sensor	18	OUT8	Crankcase heater
8	TS3	HP2: Middle pressure switch	19	K9	Relay for PFC
9	TS4	HP1: High pressure switch	20	FAN1	DC Fan
10	TS5	LPS: Low pressure sensor	21	/	Common mode inductance
11	AC	Power supply			



3) PCB A, 14-16kW, Drive PCB

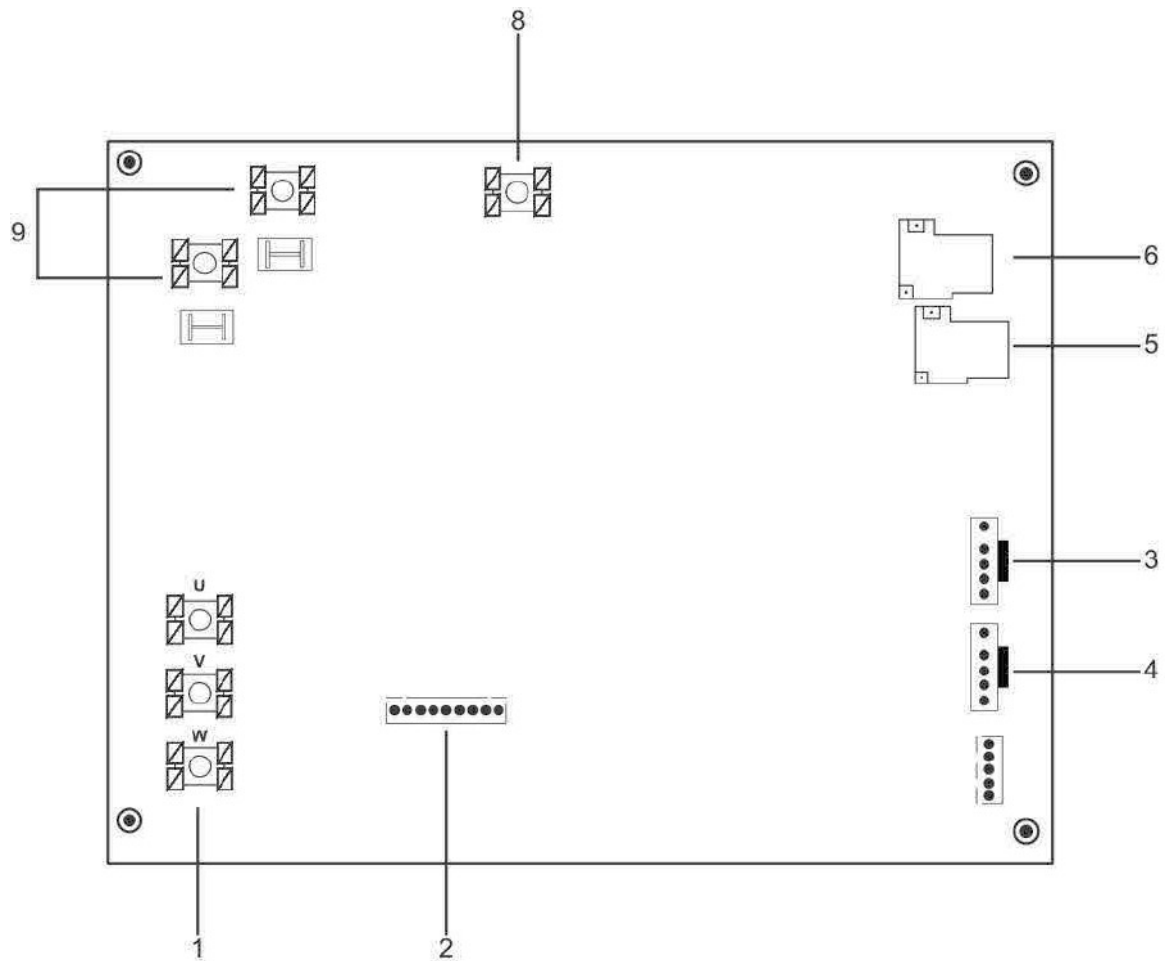

Items	Port label	Function
1	U/V/W	Compressor output
2	JTAG	Drive program update
3	FAN1	DC fan
4	FAN2	Reserved
5	K2	Relay for PFC
6	K1	Relay for PFC
7	/	Filter components --
8	PE	Port for ground
9	AC	Power supply
10	/	Drive components

4) PCB B, 14-16kW, Refrigerant system PCB

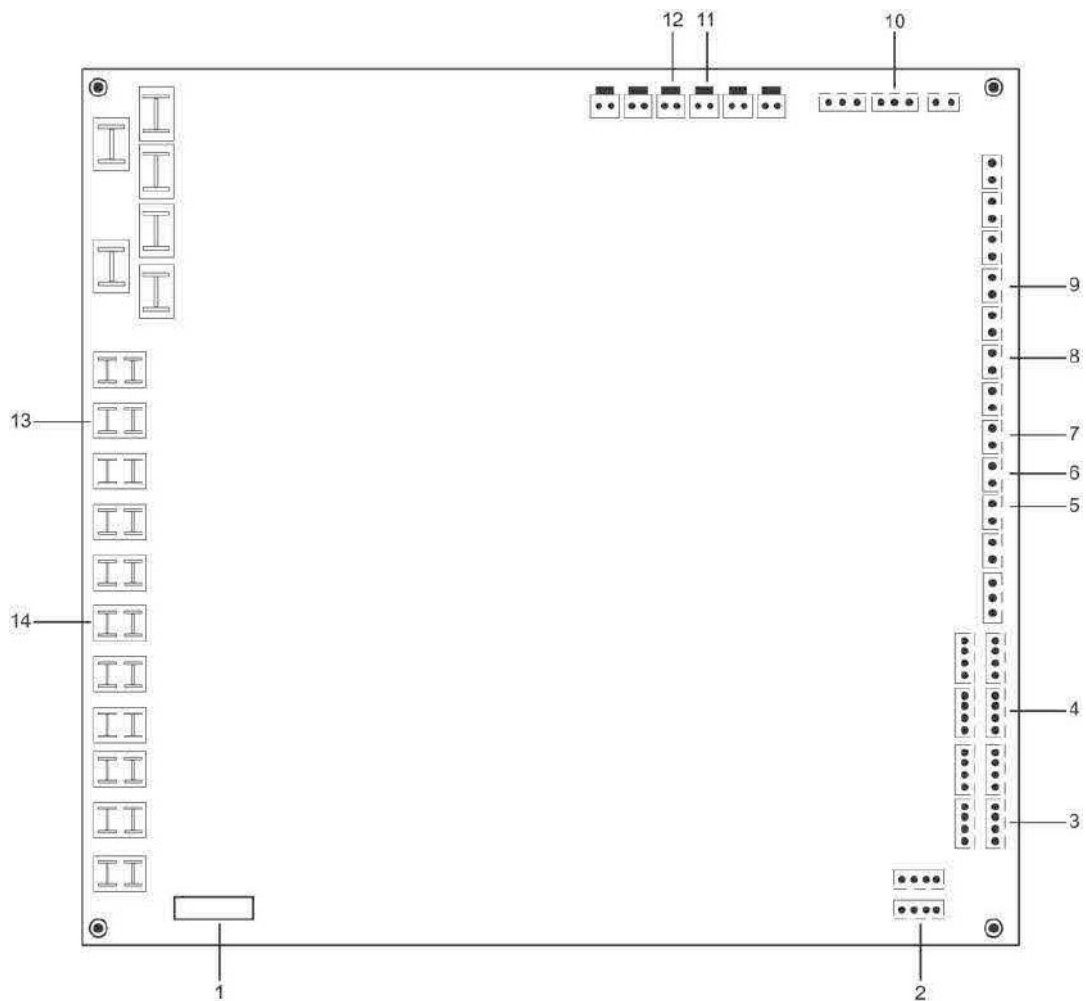

Items	Port label	Function
1	AC (L/N)	Power supply
2	EXV1	Electric expansive valve
3	COM_L/I	Communication with hydraulic module PCB
4	COM_D	Communication with inverter module PCB
5	TH1	T3: Coil temperature sensor
6	TH2	T4: Outdoor ambient temperature sensor
7	TH3	T5: liquid temperature sensor
8	TH5	TP: Discharge temperature sensor
9	TH7	TH: Suction temperature sensor
10	TS8	LPS: Low pressure sensor
11	TS4	HP2: Middle pressure switch
12	TS3	HP1: High pressure switch
13	Output 4	4 - way valve
14	Output 8	Crankcase heater
15	Output 5	Chassis heater

5) 3-phase for 12-16kW units

PCB A, 3-phase for 12-16kW, Drive and refrigerant system PCB

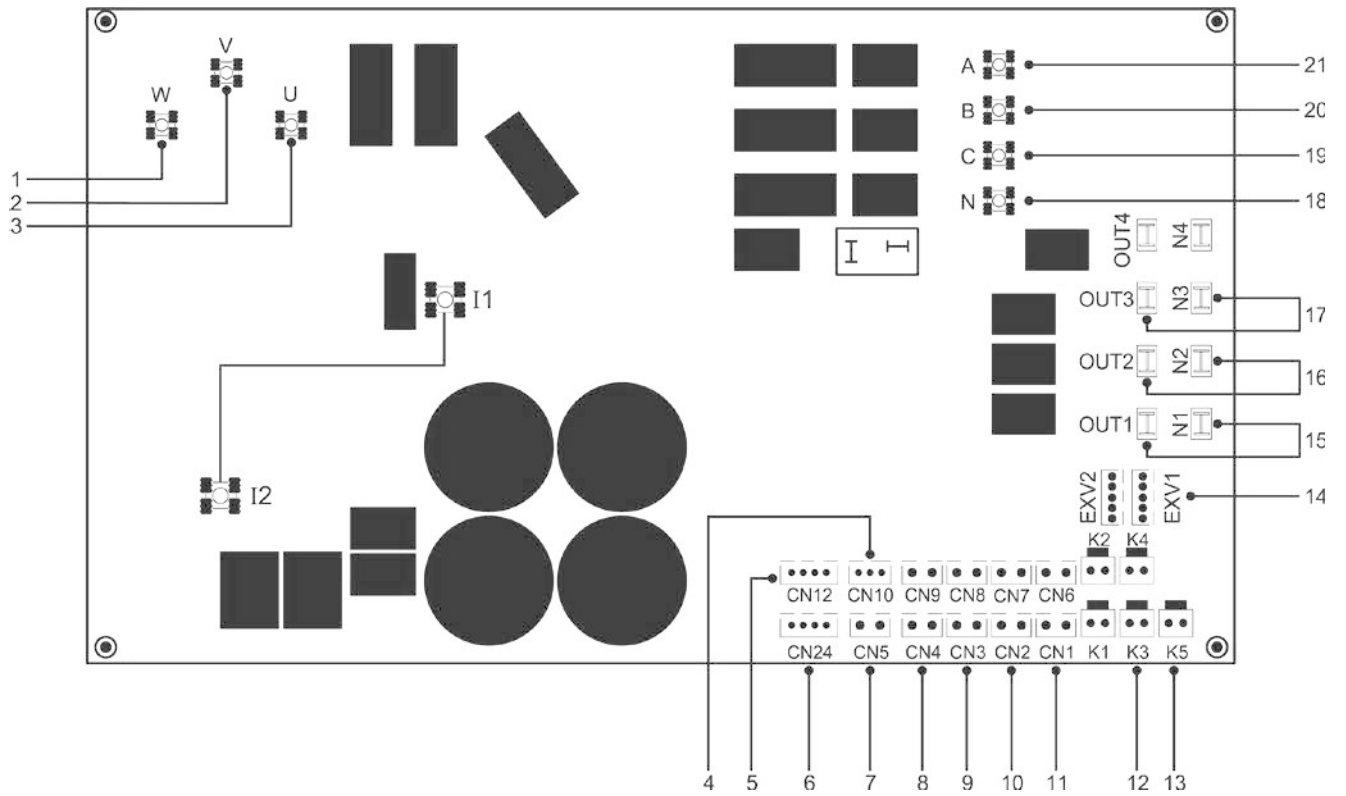

Items	Port label	Function	Items	Port label	Function
1	u	Compressor connection port	12	K3	Medium pressure switch
2	v		13	K5	High pressure switch
3	w		14	EXV1	Electronic expansion valve
4	CN10	Low pressure sensor	15	OUT1,N1	Four way valve
5	CN12	Communication between PCB A and PCB B	16	OUT2,N2	Chassis heater
6	CN24	Communication between control board 1 and control board 2	17	OUT3,N3	Crankcase heater
7	CN5	Suction temperature	18	N	Power supply
8	CN4	Discharge temperature	19	C	
9	CN3	EEV Liquid temperature	20	B	
10	CN2	Ambient temperature	21	A	
11	CN1	Coil temperature			

6) PCB B, 3-phase for 12-16kW, DC Fan drive board

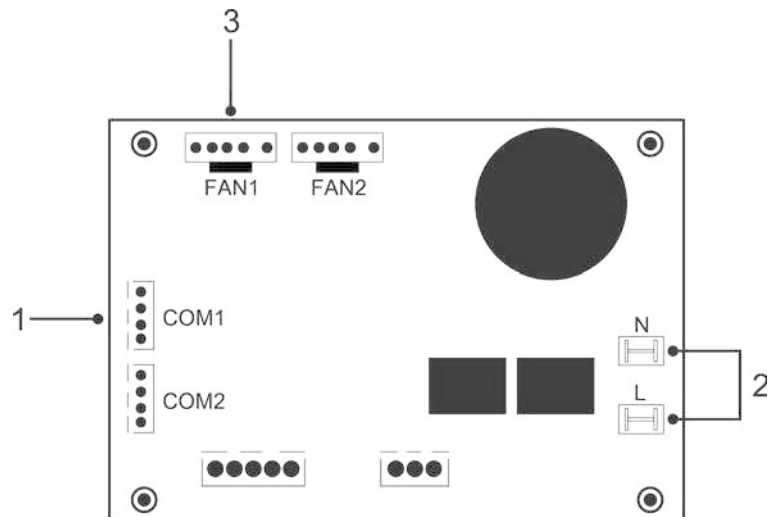

Items	Port label	Function
1	COM1	Communication between PCB A and PCB B
2	L, N	Power supply
3	FAN1	DC FAN

10 TEST RUNNING

Operate according to "key points for test running" on the electric control box cover.

CAUTION

- Test running can not start until the outdoor unit has been connected to the power for 12 hours.
- Test running can not start until all the valves are affirmed open.
- Never make the forced running .(Or the protector sits back, danger will occur.)

11 PRECAUTIONS ON REFRIGERANT LEAKAGE

When the refrigerant charge in appliance is more than 1.842kg, following requirements should be complied with.

- Requirements for charge limits in unventilated areas:

The maximum refrigerant charge in appliance shall be in accordance with the following:

$$m_{\max} = 2.5 \times (\text{LFL})^{5/4} \times 1.8 \times (A)^{1/2}$$

or the required minimum floor area A_{\min} to install an appliance with refrigerant charge m_c shall be in accordance with following:

$$A_{\min} = (m_c / (2.5 \times (\text{LFL})^{5/4} \times 1.8))^2$$

where

- m_{\max} is the allowable maximum charge in a room, in kg
- A is the room area, in m^2
- A_{\min} is the required minimum room area, in m^2
- m_c is the refrigerant charge in appliance, in kg
- LFL is the lower flammable limit in kg/m^3 , the value is 0.306 for R32 refrigerant

- Install mechanical ventilator to reduce the refrigerant thickness, under critical level. (ventilate regularly).
- Install leak alarm facility related to mechanical ventilator if you can not regularly ventilate.

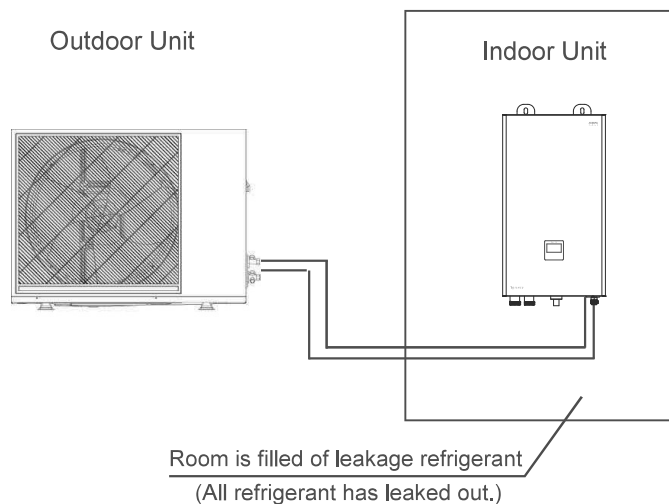

4/6/8 kW

Fig.11-1

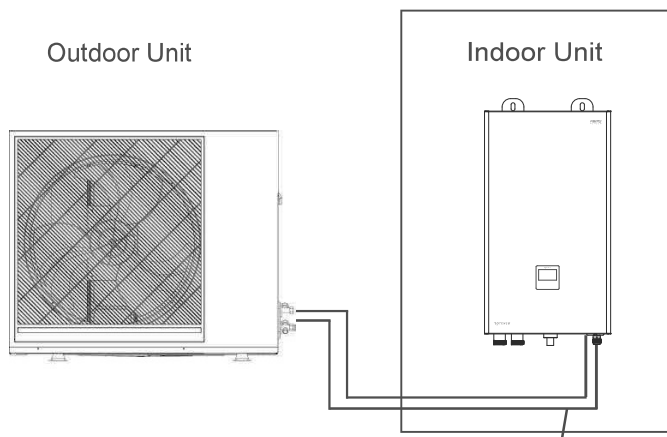

Room is filled of leakage refrigerant.
(All refrigerant has leaked out.)

10/12 kW

Fig.11-2

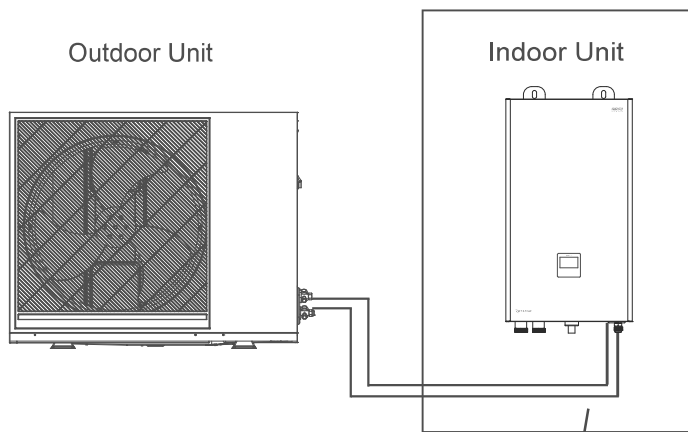

Room is filled of leakage refrigerant.
(All refrigerant has leaked out.)

14/16 kW

Fig.11-3

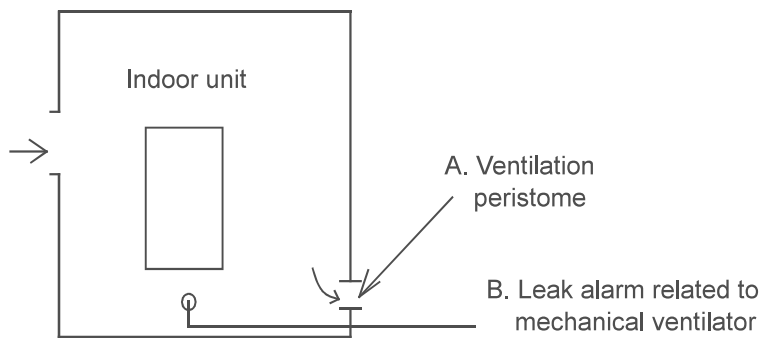

(Leak hunting siren should be installed
in places easily keep refrigerant)

Fig.11-4

12 TURN OVER TO CUSTOMER

The owner's manual of indoor unit and owner's manual of outdoor unit must be turned over to the customer. Explain the contents in the owner's manual to the customers in details.

WARNING

- **Ask your dealer for installation of the heat pump.**
Incomplete installation performed by yourself may result in a water leakage, electric shock, and fire.
- **Ask your dealer for improvement, repair, and maintenance.**
Incomplete improvement, repair, and maintenance may result in a water leakage, electric shock, and fire.
- **In order to avoid electric shock, fire or injury, or if you detect any abnormality such as smell of fire, turn off the power supply and call your dealer for instructions.**
- **Never let the indoor unit or the remote controller get wet.**
It may cause an electric shock or a fire.
- **Never press the button of the remote controller with a hard, pointed object.**
The remote controller may be damaged.
- **Never replace a fuse with that of wrong rated current or other wires when a fuse blows out.**
Use of wire or copper wire may cause the unit to break down or cause a fire.
- **It is not good for your health to expose your body to the air flow for a long time.**
- **Do not insert fingers, rods or other objects into the air inlet or outlet.**
When the fan is rotating at high speed, it will cause injury.
- **Never use a flammable spray such as hair spray, lacquer or paint near the unit.**
It may cause a fire.
- **Never put any objects into the air inlet or outlet.**
Objects touching the fan at high speed can be dangerous.
- **Do not dispose this product as unsorted municipal waste. Collection of such waste separately for special treatment is necessary.**
Do not dispose of electrical appliances as unsorted municipal waste, use separate collection facilities. 
Contact your local government for information regarding the connection systems available.
- **If electrical appliances are disposed of in landfills or dumps, hazardous substances can leak into the ground and get into the food chain, damaging your health and well-being.**
- **To prevent refrigerant leak, contact your dealer.**
When the system is installed and runs in a small room, it is required to keep the concentration of the refrigerant, if by any chance coming out, below the limit. Otherwise, oxygen in the room may be affected, resulting in a serious accident.
- **The refrigerant in the heat pump is safe and normally does not leak.**
If the refrigerant leaks in the room, contact with a fire of a burner, a heater or a cooker may result in a harmful gas.

- **Turn off any combustible heating devices, ventilate the room, and contact the dealer where you purchased the unit.**
Do not use the heat pump until a service person confirms that the portion where the refrigerant leaks is repaired.

CAUTION

- **Do not use the heat pump for other purposes.**
In order to avoid any quality deterioration, do not use the unit for cooling precision instruments, food, plants, animals or works of art.
- **Before cleaning, be sure to stop the operation, turn the breaker off or pull out the supply cord.**
Otherwise, an electric shock and injury may result.
- **In order to avoid electric shock or fire, make sure that an earth leak detector is installed.**
- **Be sure the heat pump is grounded.**
In order to avoid electric shock, make sure that the unit is grounded and that the earth wire is not connected to gas or water pipe, lightning conductor or telephone earth wire.
- **In order to avoid injury, do not remove the fan guard of the outdoor unit.**
- **Do not operate the heat pump with a wet hand.**
An electric shock may happen.
- **Do not touch the heat exchanger fins.**
These fins are sharp and could result in cutting injuries.
- **Do not place items which might be damaged by moisture under the indoor unit.**
Condensation may form if the humidity is above 80%, the drain outlet is blocked or the filter is polluted.
- **After a long use, check the unit stand and fitting for damage.**
If damaged, the unit may fall and result in injury.
- **To avoid oxygen deficiency, ventilate the room sufficiently if equipment with burner is used together with the heat pump.**
- **Arrange the drain hose to ensure smooth drainage.**
Incomplete drainage may cause wetting of the building, furniture etc.
- **Never touch the internal parts of the controller.**
Do not remove the front panel. Some parts inside are dangerous to touch, and a machine trouble may happen.
- **Never do the maintenances work by yourself.**
Please contact your local dealer to do the maintenances work.

- **Never expose little children, plants or animals directly to the air flow.**
Adverse influence to little children, animals and plants may result.
- **Do not allow a child to mount on the outdoor unit or avoid placing any object on it.**
Falling or tumbling may result in injury.
- **Do not operate the heat pump when using a room fumigation - type insecticide.**
Failure to observe could cause the chemicals to become deposited in the unit, which could endanger the health of those who are hypersensitive to chemicals.
- **Do not place appliances which produce open fire in places exposed to the air flow from the unit or under the indoor unit.**
It may cause incomplete combustion or deformation of the unit due to the heat.
- **Do not install the heat pump at any place where flammable gas may leak out.**
If the gas leaks out and stays around the heat pump, a fire may break out.
- **The appliance is not intended for use by young children or infirm persons without supervision.**
- **Young children should be supervised to ensure that they do not play with the appliance.**
- **The outdoor unit window-shades should be periodic cleaning in case of being jammed.**
This window-shapes is heat dissipation outlet of components, if being jammed will cause the components shorten their service life spans because of overheated for a long time.
- **The temperature of refrigerant circuit will be high, please keep the interconnection cable away from the copper tube.**

13 OPERATION AND PERFORMANCE

13.1 Protection Equipment

This Protection Equipment will enable the Heat Pump to stop when the Heat Pump is to be directed running compulsively.

The protection equipment may be activated in following conditions:

- **Cooling Operation**
 - The air inlet or air outlet of outdoor unit is blocked.
 - Strong wind is Continuously blowing to the air outlet of the outdoor unit.
- **Heating Operation**
 - Too much rubbish adhere to the filter in the water system
 - The air outlet of indoor unit is choked
- Mishandling in operation:
If mishandling happens because of lighting or mobile wireless, please shut off the manual power switch, and turn on again, then push the ON/OFF button.

NOTE

When the protection equipment starts, please shut down the manual power switch, and restart operation after problem is solved.

13.2 About power cut

- If power is cut during operation, stop all the operation immediately
- Power comes again. If the auto-restart function is set on, then the unit will auto-restart.

13.3 Heating capacity

- The heating operation is a heat-pump process that heat will be absorbed from outdoor air and released to indoor water. Once the outdoor temperature is decreased, heating capacity decreased correspondingly.
- Other heating equipment is suggested to be used together when outdoor temperature is too low.
- In some extreme cold upland that buy the indoor unit equipped with electrical heater will obtain better performance.(Refer to indoor unit owner's manual for details)

NOTE

1. The motor in outdoor Unit will continue running for 60 seconds for to remove residual heat when the outdoor Unit receiving OFF command during heating operation.
2. If the heat pump malfunction occurs because of disturb, please reconnect the heat pump to power, then turn on it again.

13.4 Compressor protection feature

- A protection feature prevents the heat pump from being activated for approximately several minutes when it restarts immediately after operation.

13.5 Cooling and heating operation

- The the indoor unit in the same system can not run cooling and heating at the same time.
- If the Heat Pump Administrator has set running mode, then the heat pump can not run on modes other than the presettled. Standby or No Priority will be displayed in the Control Panel.

13.6 Features of heating operation

- Water will not become hot immediately at the beginning of the heating operation, 3~5 minutes ago (depends on the indoor and outdoor temperature), until the indoor heat exchanger become hot, then becomes hot.
- During operation, the fan motor in the outdoor unit may stop running under high temperature.

13.7 Defrost in the heating operation

- During heating operation, outdoor unit sometimes will frost. To increase efficiency, the unit will start defrosting automatically (about 2~10 minutes), and then water will be drained out from outdoor unit.
- During defrosting, the fan motors in the outdoor unit will stop running.

13.8 Error codes

When a safety device is activated, an error code(which does't include external failure) will be displayed on the user interface.

A list of all errors and corrective actions can be found in the table below.

Reset the safety by turning the unit OFF and back ON.

In case this procedure for resetting the safety is not successful, contact your local dealer.

Fault number	Fault name	Failure analysis	Diagnosis method	Solution
P01	Water flow protection	<ol style="list-style-type: none"> 1. Lack of water in water system. 2. Water flow switch is fault. 3. Water system is blocked. 	<ol style="list-style-type: none"> 1. Check whether the valve of water replenishing is off. 2. Check whether the water flows witch is damage. 3. Check whether the Y shape filter is blocked. 	<ol style="list-style-type: none"> 1. Open the valve. 2. Change the water flows witch. 3. Clean or change the filternet.
P02	High pressure protection	<ol style="list-style-type: none"> 1. Water flow is over low. 2. High pressure switch is fault. 3. Refrigerant system is blocked. 4. EXV is locked. 	<ol style="list-style-type: none"> 1. Check whether there is water shortage or insufficient pump flow; 2. Check whether the highpressure switch is damage. 3. Check whether the refrigerant system is blocked. 4. Check whether there is EXV reset sound when the unit is standby, and power on or off. 	<ol style="list-style-type: none"> 1. Refill water or Add an additional water pump. 2. Change high pressure switch. 3. Change the filter of refrigerant system. 4.Change the EXV.
P03	Low pressure protection	<ol style="list-style-type: none"> 1. Lack of refrigerant. 2. Refrigerant system is blocked 3. The unit is not running in regulations operating condition. 	<ol style="list-style-type: none"> 1. Check whether the refrigerant system is leakage. 2. Check whether the filter in refrigerant system is blocked. 3. Check whether the outdoor ambient and the inlet water temperature is normal. 	<ol style="list-style-type: none"> 1. Repair the leakage point. 2. Change the filter of refrigerant system. 3. If the ambient temperature and water temperature is too high or low,the unit will stop.
P04	Condenser temperature over-heat protection	<ol style="list-style-type: none"> 1. Airflow of outdoor fan is insufficient. 2. Condenser is too dirty. 3. The temperature sensor (T3) is fault. 	<ol style="list-style-type: none"> 1. Check whether there is any obstacle which is preventing the airflow. 2. Check whether the condenser is too dirty. 3. Check whether the condenser pipe temperature sensor(T3) is normal. 	<ol style="list-style-type: none"> 1. Clean the vents 2. Clean the condenser. 3. Replace the temperature sensor.
P05	Discharge temperature protection	<ol style="list-style-type: none"> 1. Lack of refrigerant. 2. Discharge temperature sensor is fault. 	<ol style="list-style-type: none"> 1. Check whether the refrigerant system is leakage. 2. Check whether the discharge temperature sensor is normal. 	<ol style="list-style-type: none"> 1. Repair the leakage point. 2. Replace the temperature sensor
P06	Anti-freezing protection of leaving water	<ol style="list-style-type: none"> 1. Water flow is too low. 2. Heat-exchanger is blocked. 3. Y shape filter in water system is blocked. 4. Load is too low. 	<ol style="list-style-type: none"> 1. Check whether there is some air in water circuit system. 2. Check whether the heat-exchanger is blocked. 3. Check whether the Y shape filter is blocked. 4. Check whether the water circuit system is reasonable. 	<ol style="list-style-type: none"> 1. If there is a problem with the drain valve, replace it with a new one; 2. Blow the plate heat exchanger with water or high-pressure gas in the opposite direction for cleaning; 3. Clean the filter; 4. The water circulation system must have a shunt.
P07	Anti-freezing protection of condenser pipe	<ol style="list-style-type: none"> 1. Lack of refrigerant. 2. Water circuit system is blocked. 3. Refrigerant system is blocked. 	<ol style="list-style-type: none"> 1. Check for leaks in the system; 2. Check whether Y shape filter is blocked. 3. Check whether filter in refrigerant system is blocked. 	<ol style="list-style-type: none"> 1. Repair the leakage point. 2. Clean the filter. 3. Replace the filter.
P08	Middle pressure protection	Middle pressure switch off	Check whether the middle pressure switch is open circuit, when turn off the unit.	Replace the middle pressure switch.
P10	Low pressure sensor protection	<ol style="list-style-type: none"> 1. Lack of refrigerant; 2. The refrigeration system is blocked; 3. Exceeding the scope of system work. 	<ol style="list-style-type: none"> 1. Check whether the system is leaking; 2. Check if the filter net is blocked; 3. Check whether the ambient temperature or water temperature exceeds the limit. 	<ol style="list-style-type: none"> 1. Repair the leak and refill the refrigerant; 2. Replace the filter; 3. Exceed the system working limit, can't run
P11	DC fan 1 failure	<ol style="list-style-type: none"> 1. The fan is faulty or stuck; 2. The main control board is faulty 	<ol style="list-style-type: none"> 1. Check whether the fan is stuck, or replace with a new fan; 2. Replace the main control board 	<ol style="list-style-type: none"> 1. Check if the fan is stuck, or replace with a new fan; 2. Replace the main control board

Fault number	Fault name	Failure analysis	Diagnosis method	Solution
P13	4-way valve fault	<ol style="list-style-type: none"> 1. Entering/leaving water temperature sensors are reversely inserted. 2. 4-way valve is fault. 3. PCB is fault. 	<ol style="list-style-type: none"> 1. Check whether the entering and leaving temperature sensors are reversely inserted. 2. Check whether action of 4-way valve is normal. 3. Check whether the sample temperature of motherboard is accurate 	<ol style="list-style-type: none"> 1. Correct the wrong place; 2. Try to switch repeatedly to see if it works, if not, replace it; 3. If it is wrong, replace it;
P21	DC pump is abnormal	<ol style="list-style-type: none"> 1. The water pump is faulty or stuck; 2. The system lacks water and is blocked; 3. Main control board failure 	<ol style="list-style-type: none"> 1. Check whether the water pump is blocked, or replace with a new water pump; 2. Check whether the system is short of water, whether it is blocked, and whether the valve is closed; 3. Replace the main control board 	<ol style="list-style-type: none"> 1. Check if the water pump is blocked, or replace with a new water pump; 2. Refill water or clean or replace the filter net and open the valve; 3. Replace the main control board
P25	Outlet pressure sensor failure	<ol style="list-style-type: none"> 1. The sensor connection line is open or short-circuited; 2. Sensor failure; 3. The main control board is faulty; 	<ol style="list-style-type: none"> 1. Use a multimeter to check whether the sensor and connection are abnormal; 2. Replace the faulty sensor with a normal sensor to confirm whether it is normal; 3. Replace the main control board and confirm whether it is normal 	<ol style="list-style-type: none"> 1. Repair the connecting wire and plug or replace the sensor; 2. Replace the motherboard;
E01	Communication error of controller	<ol style="list-style-type: none"> 1. The communication cable is disconnected; 2. The wire controller is faulty; 3. The main control board is faulty; 	<ol style="list-style-type: none"> 1. Check whether the communication cable is open or the plug is in poor contact; 2. Confirm whether the wire controller is normal on a normal machine; 3. Use a normal wire controller to confirm whether it is normal on the faulty machine; 	<ol style="list-style-type: none"> 1. Replace the communication cable or repair; 2. Replace the line controller; 3. Replace the main control board;
E02	TP exhaust temperature sensor failure	<ol style="list-style-type: none"> 1. The sensor connection line is open or short-circuited; 2. Sensor failure; 3. The main control board is faulty; 	<ol style="list-style-type: none"> 1. Use a multimeter to check whether the sensor and connection are abnormal; 2. Replace the faulty sensor with a normal sensor to confirm whether it is normal; 3. Replace the main control board and confirm whether it is normal; 	<ol style="list-style-type: none"> 1. Repair the connecting wire and plug or replace the sensor; 2. Replace the motherboard;
E03	T3 coil temperature sensor failure	<ol style="list-style-type: none"> 1. The sensor connection line is open or short-circuited; 2. Sensor failure; 3. Main control board failure 	<ol style="list-style-type: none"> 1. Use a multimeter to check whether the sensor and connection are abnormal; 2. Replace the faulty sensor with a normal sensor to confirm whether it is normal; 3. Replace the main control board and confirm whether it is normal; 	<ol style="list-style-type: none"> 1. Repair the connecting wire and plug or replace the sensor; 2. Replace the motherboard;
E04	T4 Ambient temperature sensor failure	<ol style="list-style-type: none"> 1. The sensor connection line is open or short-circuited; 2. Sensor failure; 3. Main control board failure 	<ol style="list-style-type: none"> 1. Use a multimeter to check whether the sensor and connection are abnormal; 2. Replace the faulty sensor with a normal sensor to confirm whether it is normal; 3. Replace the main control board and confirm whether it is normal; 	<ol style="list-style-type: none"> 1. Repair the connecting wire and plug or replace the sensor; 2. Replace the motherboard;
E05	T5 liquid pipe temperature sensor failure	<ol style="list-style-type: none"> 1. The sensor connection line is open or short-circuited; 2. Sensor failure; 3. Main control board failure 	<ol style="list-style-type: none"> 1. Use a multimeter to check whether the sensor and connection are abnormal; 2. Replace the faulty sensor with a normal sensor to confirm whether it is normal; 3. Replace the main control board and confirm whether it is normal; 	<ol style="list-style-type: none"> 1. Repair the connecting wire and plug or replace the sensor; 2. Replace the motherboard;
E06	TH return air temperature sensor failure	<ol style="list-style-type: none"> 1. The sensor connection line is open or short-circuited; 2. Sensor failure; 3. Main control board failure 	<ol style="list-style-type: none"> 1. Use a multimeter to check whether the sensor and connection are abnormal; 2. Replace the faulty sensor with a normal sensor to confirm whether it is normal; 3. Replace the main control board and confirm whether it is normal; 	<ol style="list-style-type: none"> 1. Repair the connecting wire and plug or replace the sensor; 2. Replace the motherboard;

Fault number	Fault name	Failure analysis	Diagnosis method	Solution
E07	TW water tank temperature sensor failure	1. The sensor connection line is open or short-circuited; 2. Sensor failure; 3. Main control board failure	1. Use a multimeter to check whether the sensor and connection are abnormal; 2. Replace the faulty sensor with a normal sensor to confirm whether it is normal; 3. Replace the main control board and confirm whether it is normal;	1. Repair the connecting wire and plug or replace the sensor; 2. Replace the motherboard;
E08	T6 Inlet water temperature sensor failure	1. The sensor connection line is open or short-circuited; 2. Sensor failure; 3. Main control board failure	1. Use a multimeter to check whether the sensor and connection are abnormal; 2. Replace the faulty sensor with a normal sensor to confirm whether it is normal; 3. Replace the main control board and confirm whether it is normal;	1. Repair the connecting wire and plug or replace the sensor; 2. Replace the motherboard;
E09	T7 outlet water temperature sensor failure	1. The sensor connection line is open or short-circuited; 2. Sensor failure; 3. Main control board failure	1. Use a multimeter to check whether the sensor and connection are abnormal; 2. Replace the faulty sensor with a normal sensor to confirm whether it is normal; 3. Replace the main control board and confirm whether it is normal;	1. Repair the connecting wire and plug or replace the sensor; 2. Replace the motherboard;
E10	Communication failure between main control board and drive board	1. The communication cable is disconnected; 2. The main control board is faulty; 3. The drive module is faulty;	1. Check whether the communication cable is open or the plug is in poor contact; 2. Replace the main control board and confirm whether it is normal; 3. Replace the drive board and confirm whether it is normal;	1. Replace or repair the communication cable; 2. Replace the main control board; 3. Replace the drive module;
E14	Low pressure sensor LPS failure	1. The sensor connection line is open or short-circuited; 2. Sensor failure; 3. The main control board is faulty;	1. Check whether the sensor and connection are abnormal; 2. Replace the faulty sensor with a normal sensor to confirm whether it is normal; 3. Replace the main control board and confirm whether it is normal;	1. Repair the connecting wire and plug or replace the sensor; 2. Replace the motherboard;
E15	DC bus voltage is too low	Wiring error or IPM module failure Check whether the wiring is wrong, reconnect the cable or replace the IPM module		
E16	DC bus voltage is too high			
E17	AC current protection (input current)			
E18	IPM module is abnormal			
E19	PFC abnormal			

Fault number	Fault name	Failure analysis	Diagnosis method	Solution
E20	Compressor failed to start	Wiring error or IPM module failure Check whether the wiring is wrong, reconnect the cable or replace the IPM module		
E21	Compressor phase loss			
E22	IPM Module reset			
E23	Compressor over-current			
E24	PFC module temperature is too high			
E25	Current detection circuit failure			
E26	Out of step			
E27	PFC module temperature sensor is abnormal			
E28	Communication fail			
E29	IPM module temperature is too high			
E30	IPM module temperature sensor failure			
E31	Reserved			
E32	Reserved			
E33	Reserved			
E34	AC input voltage is abnormal			
E51	The built-in temperature sensor Tro of the wire controller is faulty	Wiring error or IPM module failure Check whether the wiring is wrong, reconnect the cable or replace the IPM module		
E49	TC error the final water temperature sensor			
E52	Zone 2 temperature sensor Tw2 error			
E53	Up temperature sensor TE1 of buffer tank error			
E54	Down temperature sensor TE2 of buffer tank error			
E50	Solar temperature sensor Tso error			
E56	outlet water pressure sensor PS1 error			
E35	Drive EEPR error			
E36	Power off reset			
E37	Reserved			
E38	Reserved			

14 TECHNICAL SPECIFICATIONS

Model	4 kW	6 kW	8 kW	10 kW
Power supply	220-240V~ 50Hz			
Rated power input	1900W	2900 W	3800 W	4500 W
Rated power	8,26A	12,6 A	16,5 A	19,6 A
Norminal capacity	Refer to technical data			
Dimensions (W×H×D)[mm]	971 × 425 × 703			999 × 448 × 803
Packing (W×H×D)[mm]	1025 × 465 × 865			1045 × 458 × 970
Fan motor	DC motor / Horizontal			
Compressor	DC inverter dual rotary			
Heat exchanger	Fin-coil			
Refrigerant				
Type	R32			
Quantity	1400 g		1500 g	1600 g
Weight				
Net weight	56 kg		58 kg	72 kg
Gross weight	67 kg		69 kg	83 kg
Connections				
Gas side	φ6,35		φ9,52	
Liquid side	φ15,9		φ15,9	
Drain connection	DN32			
Max. piping length	15m			
Max. difference in height	8m			
Refrigerant to be added	20g/m		38g/m	
Operation ambient temperature range				
Heating mode	-25~+35°C			
Cooling mode	-5~+43°C			
Domestic hot water mode	-25~+43°C			

Model	12 kW	14 kW	16 kW
Power supply	380-415V~ 50Hz		
Rated power input	5700W	5900 W	7500 W
Rated power	8,3A	8,6 A	10,9 A
Norminal capacity	Refer to technical data		
Dimensions (W×H×D)[mm]	999 × 448 × 803	1099 × 436 × 854	
Packing (W×H×D)[mm]	1045 × 458 × 970	1165 × 495 × 1040	
Fan motor	DC motor / Horizontal		
Compressor	DC inverter dual rotary		
Heat exchanger	Fin-coil		
Refrigerant			
Type	R32		
Quantity	1750 g	1840 g	
Weight			
Net weight	83 kg	108 kg	
Gross weight	92 kg	123 kg	
Connections			
Gas side	φ9,52		
Liquid side	φ15,9		
Drain connection	DN32		
Max. piping length	15m		
Max. difference in height	8m		
Refrigerant to be added	38g/m		
Operation ambient temperature range			
Heating mode	-25~+35°C		
Cooling mode	-5~+43°C		
Domestic hot water mode	-25~+43°C		

15 INFORMATION SERVICING

1) Checks to the area

Prior to beginning work on systems containing flammable refrigerants, safety checks are necessary to ensure that the risk of ignition is minimised. For repair to the refrigerating system, the following precautions shall be complied with prior to conducting work on the system.

2) Work procedure

Works shall be undertaken under a controlled procedure so as to minimise the risk of a flammable gas or vapour being present while the work is being performed.

3) General work area

All maintenance staff and others working in the local area shall be instructed on the nature of work being carried out, work in confined spaces shall be avoided. The area around the work space shall be sectioned off. Ensure that the conditions within the area have been made safe by control of flammable material.

4) Checking for presence of refrigerant

The area shall be checked with an appropriate refrigerant detector prior to and during work, to ensure the technician is aware of potentially flammable atmospheres. Ensure that the leak detection equipment being used is suitable for use with flammable refrigerants, i.e. no sparking, adequately sealed or intrinsically safe.

5) Presence of fire extinguisher

If any hot work is to be conducted on the refrigeration equipment or any associated parts, appropriate fire extinguishing equipment shall be available to hand. Have a dry power or CO₂ fire extinguisher adjacent to the charging area.

6) No ignition sources

No person carrying out work in relation to a refrigeration system which involves exposing any pipe work that contains or has contained flammable refrigerant shall use any sources of ignition in such a manner that it may lead to the risk of fire or explosion. All possible ignition sources, including cigarette smoking, should be kept sufficiently far away from the site of installation, repairing, removing and disposal, during which flammable refrigerant can possibly be released to the surrounding space. Prior to work taking place, the area around the equipment is to be surveyed to make sure that there are no flammable hazards or ignition risks. NO SMOKING signs shall be displayed.

7) Ventilated area

Ensure that the area is in the open or that it is adequately ventilated before breaking into the system or conducting any hot work. A degree of ventilation shall continue during the period that the work is carried out. The ventilation should safely disperse any released refrigerant and preferably expel it externally into the atmosphere.

8) Checks to the refrigeration equipment

Where electrical components are being changed, they shall be fit for the purpose and to the correct specification. At all times the manufacturer's maintenance and service guidelines shall be followed. If in doubt consult the manufacturer's technical department for assistance. The following checks shall be applied to installations using flammable refrigerants:

- The charge size is in accordance with the room size within which the refrigerant containing parts are installed;
- The ventilation machinery and outlets are operating adequately and are not obstructed;
- If an indirect refrigerating circuit is being used, the secondary circuits shall be checked for the presence of refrigerant; marking to the equipment continues to be visible and legible.
- Marking and signs that are illegible shall be corrected;
- Refrigeration pipe or components are installed in a position where they are unlikely to be exposed to any substance which may corrode refrigerant containing components, unless the components are constructed of materials which are inherently resistant to being corroded or are suitably protected against being so corroded.

9) Checks to electrical devices

Repair and maintenance to electrical components shall include initial safety checks and component inspection procedures. If a fault exists that could compromise safety, then no electrical supply shall be connected to the circuit until it is satisfactorily dealt with. If the fault cannot be corrected immediately but it is necessary to continue operation, and adequate temporary solution shall be used. This shall be reported to the owner of the equipment so all parties are advised.

Initial safety checks shall include:

- That capacitors are discharged: this shall be done in a safe manner to avoid possibility of sparking;
- That there no live electrical components and wiring are exposed while charging, recovering or purging the system;
- That there is continuity of earth bonding.

10) Repairs to sealed components

a) During repairs to sealed components, all electrical supplies shall be disconnected from the equipment being worked upon prior to any removal of sealed covers, etc. If it is absolutely necessary to have an electrical supply to equipment during servicing, then a permanently operating form of leak detection shall be located at the most critical point to warn of a potentially hazardous situation.

b) Particular attention shall be paid to the following to ensure that by working on electrical components, the casing is not altered in such a way that the level of protection is affected. This shall include damage to cables, excessive number of connections, terminals not made to original specification, damage to seals, incorrect fitting of glands, etc.

- Ensure that apparatus is mounted securely.
- Ensure that seals or sealing materials have not degraded such that they no longer serve the purpose of preventing the ingress of flammable atmospheres. Replacement parts shall be in accordance with the manufacturer's specifications.

NOTE

The use of silicon sealant may inhibit the effectiveness of some types of leak detection equipment. Intrinsically safe components do not have to be isolated prior to working on them.

11) Repair to intrinsically safe components

Do not apply any permanent inductive or capacitance loads to the circuit without ensuring that this will not exceed the permissible voltage and current permitted for the equipment in use. Intrinsically safe components are the only types that can be worked on while live in the presence of a flammable atmosphere. The test apparatus shall be at the correct rating. Replace components only with parts specified by the manufacturer. Other parts may result in the ignition of refrigerant in the atmosphere from a leak.

12) Cabling

Check that cabling will not be subject to wear, corrosion, excessive pressure, vibration, sharp edges or any other adverse environmental effects. The check shall also take into account the effects of aging or continual vibration from sources such as compressors or fans.

13) Detection of flammable refrigerants

Under no circumstances shall potential sources of ignition be used in the searching for or detection of refrigerant leaks. A halide torch (or any other detector using a naked flame) shall not be used.

14) Leak detection methods

The following leak detection methods are deemed acceptable for systems containing flammable refrigerants. Electronic leak detectors shall be used to detect flammable refrigerants, but the sensitivity may not be adequate, or may need re-calibration. (Detection equipment shall be calibrated in a refrigerant-free area.) Ensure that the detector is not a potential source of ignition and is suitable for the refrigerant. Leak detection equipment shall be set at a percentage of the LFL of the refrigerant and shall be calibrated to the refrigerant employed and the appropriate percentage of gas (25% maximum) is confirmed. Leak detection fluids are suitable for use with most refrigerants but the use of detergents containing chlorine shall be avoided as the chlorine may react with the refrigerant and corrode the copper pipe-work. If a leak is suspected, all naked flames shall be removed or extinguished. If a leakage of refrigerant is found which requires brazing, all of the refrigerant shall be recovered from the system, or isolated (by means of shut off valves) in a part of the system remote from the leak. Oxygen free nitrogen (OFN) shall then be purged through the system both before and during the brazing process.

15) Removal and evacuation

When breaking into the refrigerant circuit to make repairs or for any other purpose conventional procedures shall be used. However, it is important that best practice is followed since flammability is a consideration. The following procedure shall be adhered to:

- Remove refrigerant;
- Purge the circuit with inert gas;
- Evacuate;
- Purge again with inert gas;
- Open the circuit by cutting or brazing.

The refrigerant charge shall be recovered into the correct recovery cylinders. The system shall be flushed with OFN to render the unit safe. This process may need to be repeated several times.

Compressed air or oxygen shall not be used for this task.

Flushing shall be achieved by breaking the vacuum in the system with OFN and continuing to fill until the working pressure is achieved, then venting to atmosphere, and finally pulling down to a vacuum. This process shall be repeated until no refrigerant is within the system.

When the final OFN charge is used, the system shall be vented down to atmospheric pressure to enable work to take place. This operation is absolutely vital if brazing operations on the pipe-work are to take place.

Ensure that the outlet for the vacuum pump is not closed to any ignition sources and there is ventilation available.

16) Charging procedures

In addition to conventional charging procedures, the following requirements shall be followed:

- Ensure that contamination of different refrigerants does not occur when using charging equipment. Hoses or lines shall be as short as possible to minimize the amount of refrigerant contained in them.

Cylinders shall be kept upright.

Ensure that the refrigeration system is earthed prior to charging the system with refrigerant.

Label the system when charging is complete (if not already).

Extreme care shall be taken not to overfill the refrigeration system.

Prior to recharging the system it shall be pressure tested with OFN. The system shall be leak tested on completion of charging but prior to commissioning. A follow up leak test shall be carried out prior to leaving the site.

17) Decommissioning

Before carrying out this procedure, it is essential that the technician is completely familiar with the equipment and all its detail. It is recommended good practice that all refrigerants are recovered safely. Prior to the task being carried out, an oil and refrigerant sample shall be taken.

In case analysis is required prior to re-use of reclaimed refrigerant. It is essential that electrical power is available before the task is commenced.

a) Become familiar with the equipment and its operation.

b) Isolate system electrically

c) Before attempting the procedure ensure that:

- Mechanical handling equipment is available, if required, for handling refrigerant cylinders;
- All personal protective equipment is available and being used correctly;
- The recovery process is supervised at all times by a competent person;
- Recovery equipment and cylinders conform to the appropriate standards.

d) Pump down refrigerant system, if possible.

e) If a vacuum is not possible, make a manifold so that refrigerant can be removed from various parts of the system.

f) Make sure that cylinder is situated on the scales before recovery takes place.

g) Start the recovery machine and operate in accordance with manufacturer's instructions.

h) Do not overfill cylinders. (No more than 80% volume liquid charge).

i) Do not exceed the maximum working pressure of the cylinder, even temporarily.

j) When the cylinders have been filled correctly and the process completed, make sure that the cylinders and the equipment are removed from site promptly and all isolation valves on the equipment are closed off.

k) Recovered refrigerant shall not be charged into another refrigeration system unless it has been cleaned and checked.

18) Labelling

Equipment shall be labelled stating that it has been de-commissioned and emptied of refrigerant. The label shall be dated and signed. Ensure that there are labels on the equipment stating the equipment contains flammable refrigerant.

19) Recovery

When removing refrigerant from a system, either for service or decommissioning, it is recommended good practice that all refrigerants are removed safely.

When transferring refrigerant into cylinders, ensure that only appropriate refrigerant recovery cylinders are employed. Ensure that the correct numbers of cylinders for holding the total system charge are available. All cylinders to be used are designated for the recovered refrigerant and labelled for that refrigerant (i.e. special cylinders for the recovery of refrigerant). Cylinders shall be complete with pressure relief valve and associated shut-off valves in good working order.

Empty recovery cylinders are evacuated and, if possible, cooled before recovery occurs.

The recovery equipment shall be in good working order with a set of instructions concerning the equipment that is at hand and shall be suitable for the recovery of flammable refrigerants. In addition, a set of calibrated weighing scales shall be available and in good working order.

Hoses shall be complete with leak-free disconnect couplings and in good condition. Before using the recovery machine, check that it is in satisfactory working order, has been properly maintained and that any associated electrical components are sealed to prevent ignition in the event of a refrigerant release. Consult manufacturer if in doubt.

The recovered refrigerant shall be returned to the refrigerant supplier in the correct recovery cylinder, and the relevant Waste Transfer Note arranged. Do not mix refrigerants in recovery units and especially not in cylinders.

If compressors or compressor oils are to be removed, ensure that they have been evacuated to an acceptable level to make certain that flammable refrigerant does not remain within the lubricant. The evacuation process shall be carried out prior to returning the compressor to the suppliers. Only electric heating to the compressor body shall be employed to accelerate this process. When oil is drained from a system, it shall be carried out safely.

20) Transportation, marking and storage for units

Transport of equipment containing flammable refrigerants Compliance with the transport regulations

Marking of equipment using signs Compliance with local regulations

Disposal of equipment using flammable refrigerants Compliance with national regulations

Storage of equipment/appliances

The storage of equipment should be in accordance with the manufacturer's instructions.

Storage of packed (unsold) equipment

Storage package protection should be constructed such that mechanical damage to the equipment inside the package will not cause a leak of the refrigerant charge.

The maximum number of pieces of equipment permitted to be stored together will be determined by local regulations.

The current versions of the installation and user manuals can be found on the distributor's website:
thermosilesia.pl

email: info@rotenso.com



INSTALLER STAMP

UM/RO/PC/AIS/ODU/PL_EN/20231102

www.rotenso.com